



2002-2006 CR-V 6 inch lift kit installation guide

Professional installation is recommended

IMPORTANT!

Lifting and modifying the suspension on your vehicle may result in drive line vibrations, damaged bushings, erratic handling characteristics, and shortened suspension component life. HRG Offroad recommends the following:

- Checking and/or replacing worn drive axles with new parts, not remanufactured.
- Checking and/or replacing all worn factory rubber bushings with urethane bushings, such as Prothane.
- Checking and/or replacing worn shock absorbers and bump stops.
- Performing a 4 wheel alignment after working on suspension components.

Lift kits may not be legal for use on public highways in your area. Please check local laws before installing!!

WARNING!

Lifted vehicles are more prone to rolling over.

Some HRG Offroad products are designed to improve off-road capabilities. Modifying the suspension of your vehicle may result in handling characteristics that are different from a factory equipped vehicle. Extreme care must be used to prevent a rollover or loss of control. Always operate your modified vehicle at a reduced speed to ensure your ability to maintain control under all driving conditions. Driving your vehicle in an unsafe manner may result in serious injury or death. HRG Offroad lift kits are designed and tested to work together. HRG Offroad does not recommend combining this lift kit with any other type of suspension or body lift. Always wear your seat belt.

Recommended tire/wheel sizes:

Stock 205/70/15 (26.3") or 215/65/16 (26.4")

15" wheels:

205/75/15 (27.0")

225/70/15 (27.4")

215/75/15 (27.7")

225/75/15 (28.2")

235/75/15 (28.8")

30x9.50R15 (30.0")

31x10.50R15 (31.0") (may require cutting)

16" wheels

215/70/16 (27.8")

235/70/16 (28.9")

225/75/16 (29.2")

235/75/16 (29.8")

255/70/16 (30.0")

265/70/16 (30.6")

Be sure to check fitment prior to installation! These sizes are only suggestions. HRG is not responsible for improperly fitted wheels/tires

Included in the kit:

2 4.5" lift spacers (front)
2 3.5" lift spacers (rear) 5208
4 M10x25mm grade 10.9 bolts
2 adjustable rear upper control arms
2 power steering hose relocation brackets
2 upper rear brake line extension brackets
2 lower rear brake line extension brackets
2 parking brake cable drop brackets
2 front brake line relocation brackets
2 trailing arm drop brackets
4 2.75x3" M12 spacers (rear subframe)
2 1.25x3" M12 spacers (engine)
1 transmission drop bracket
4 2.75x3" M14 spacers (front subframe)
2 1.25x3 M12 spacers (rear differential **4WD kit only**)
2 1x3" M10 spacers (driveshaft carrier bearing, **4WD kit only**)
2 M10x100mm bolts (driveshaft carrier bearing, **4WD kit only**)
2 M8x70mm bolts (driveshaft safety loops, **4WD kit only**)
2 0.75x2" M8 spacers (driveshaft safety loops, **4WD kit only**)
2 M12x140mm bolts (rear differential **4WD kit only**)
8 M16x100mm bolts and M16 nuts (front strut extensions)
4 M14x180mm bolts (front subframe)
2 M12x110mm bolts (engine)
3 M12x110mm bolts (transmission)
4 M12x150mm bolts (rear subframe)
4 M12x150mm bolts (trailing arms)
2 M6x100mm bolts/3" spacers/4 washers (charcoal canister)
4 Extended exhaust hangers

Tools required:

Floor Jack, lug wrench, 10mm, 18mm, 19mm, and 21mm sockets, 12mm, 14mm, 17mm sockets and wrenches, 18mm wrench, bench grinder, cutoff wheel, impact wrench, torque wrench, needle nose pliers, heavy hammer, paint pen

Installation time: 8 hours

Skill level: Moderate

Note to installer: All bolts removed to install subframe kit will be replaced with longer bolts. This kit does require cutting the OEM air box on AUTO TRANSMISSION MODELS ONLY, or replacing the air box with an

aftermarket intake. Prior to starting installation, check bolts on rear struts in lower control arm. These bolts tend to rust solid and may require cutting the struts out and replacing them, along with the bolts.

Front subframe installation:

Step 1. Support engine/transmission with floor jack, taking care not to dent oil pan.

Step 2. Disconnect and remove the battery. It may also be necessary to remove the battery tray to allow more room to work.

Step 3. Remove factory air box (if applicable) to gain access to transmission mount.

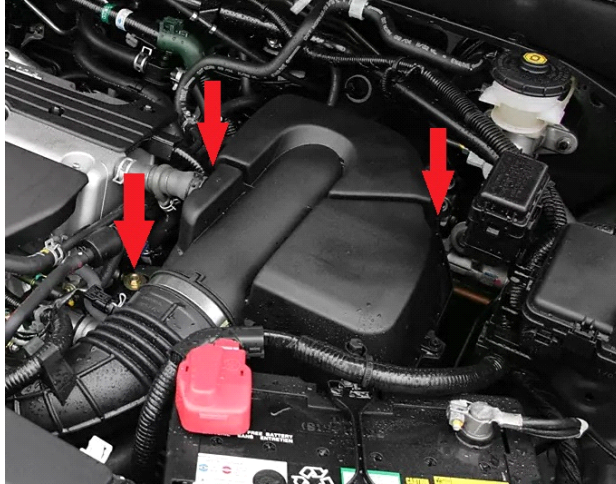

Step 4. Remove 2 M12 nuts and one M12x35 bolt holding the transmission bracket to the transmission. Step 5. Remove driver side transmission bracket.

Step 6. Remove 2 transmission studs (see diagram) This can be done by tightening 2 M12 nuts against each other and backing the studs out.

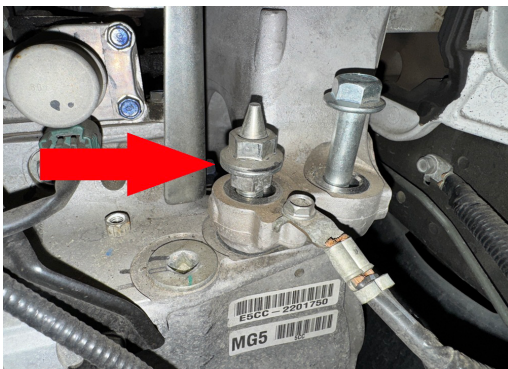

2002-2006 HONDA CR-V/ ELEMENT
TRANSMISSION STUD DIAGRAM
(C)HRG OFFROAD 2024

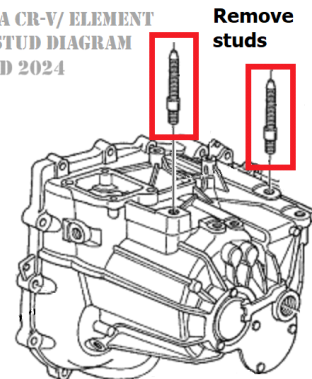

Step 7. Remove M12 nut and M12x45 bolt holding the engine mounting bracket. Remove passenger side engine bracket.

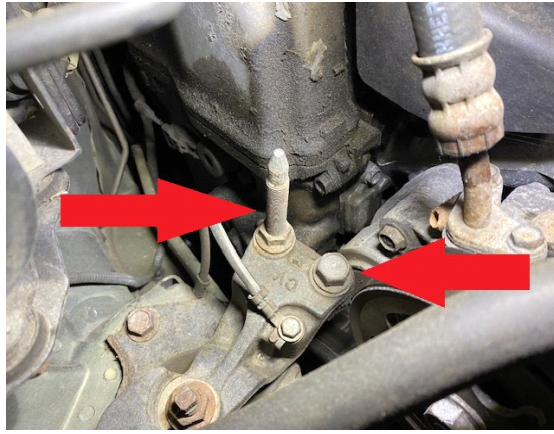

Step 8. Remove stud from engine bracket. This can be done by either welding the nut to the stud or tightening 2 M12 nuts against each other and backing the stud out.

Step 9. Remove 2 bolts holding power steering hose to radiator support. Install 2 brackets provided in the kit as shown in photo below:

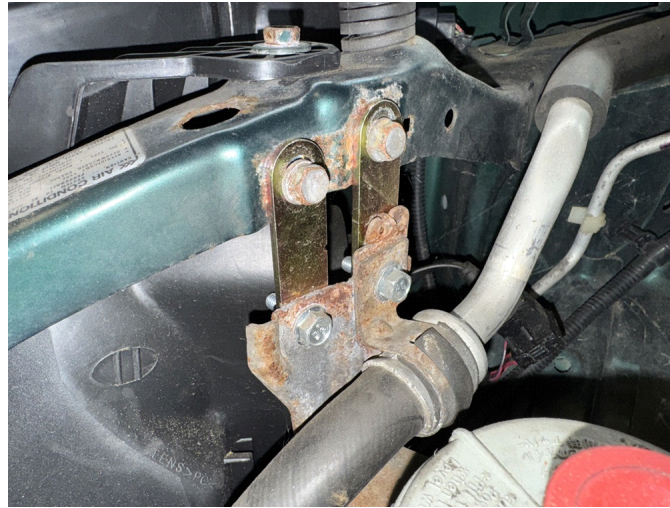

Step 10. Unclip rear engine wiring harness from bracket as shown in photo below:

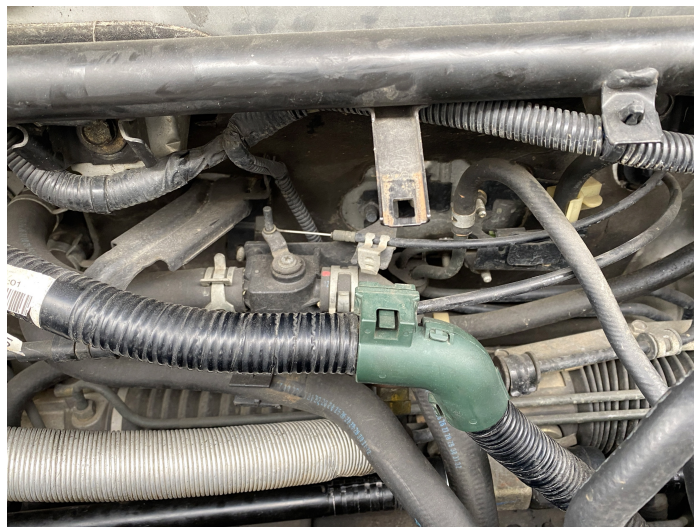

Step 11. Remove plastic splash shield under front bumper. There are several plastic clips and 10mm bolts holding this piece on.

Step 12. Reposition jack under engine, again taking care not to dent oil pan.

Step 13. Remove 2 M14 main subframe bolts (**leave 2 bolts in at all times to maintain alignment of subframe**)

Step 14. Temporarily install 2 M14x180 bolts in place of the 2 removed bolts. Remove remaining 2 factory main subframe bolts.

Step 15. Carefully lower engine and subframe assembly down approximately 3 inches with floor jack.

Step 16. Place 2 2.75x3 M14 spacers between subframe and body, install 2 more M14x180 bolts, but do not tighten at this time.

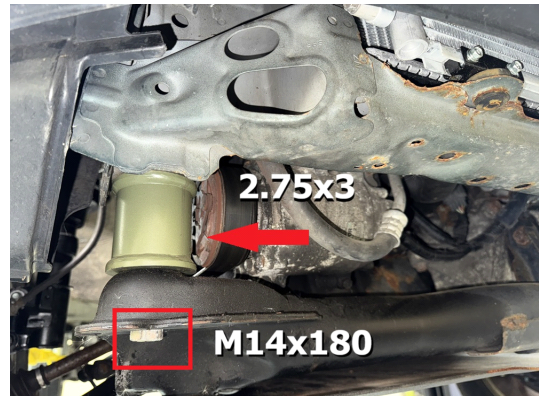

Step 17. Remove the 2 M14x180 bolts from step 13.

Step 18. Place 2 more 2.75x3 M14 spacers between subframe and body, thread in 2 M14x180 bolts, tighten all 4 subframe bolts.

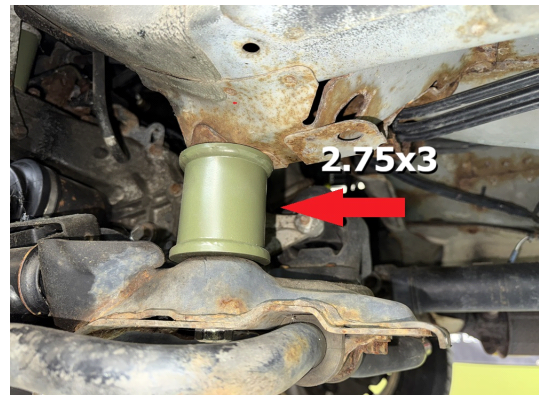

Step 19. Place 2 1.25x3 M12 spacers between engine mount and engine bracket and install 2 M12x110 bolts (see photo):

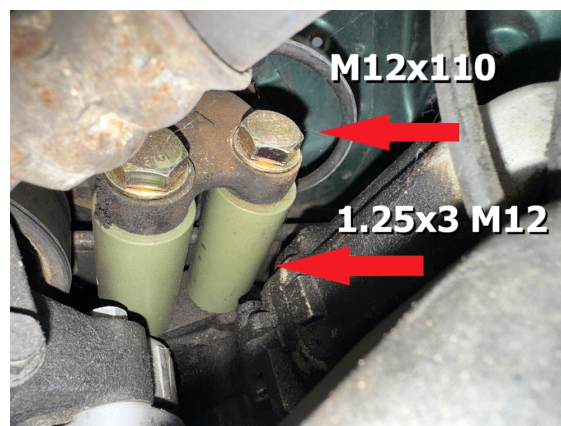

Step 20. Place transmission drop bracket between transmission and transmission mount, install 3 M12x110 bolts. (see photo)



Step 21. Place air box in position and mark areas to be trimmed for clearance on transmission bracket (Automatic Transmission models ONLY).

Step 22. Using a cutoff wheel, or cutting tool of choice, create a notch in the bottom of the air box to allow it to fit over transmission bracket, bolt back into original location using original bolts. Alternatively, install aftermarket air intake.

Step 23. Replace battery tray and battery. Leave battery disconnected until completion of installation.

NOTE: It may be necessary to adjust the position of various wiring harnesses and radiator hoses after lowering engine. Typically only the rear harness from step 9 will need to be relocated. This harness can be secured by a zip tie if necessary. The lower radiator hose will need to be trimmed or replaced with a universal flex hose.

Step 24. Lift vehicle and support with jack stands.

Step 25. Remove wheels.

Step 26. Remove brake lines and ABS wiring (if applicable) from driver side strut.

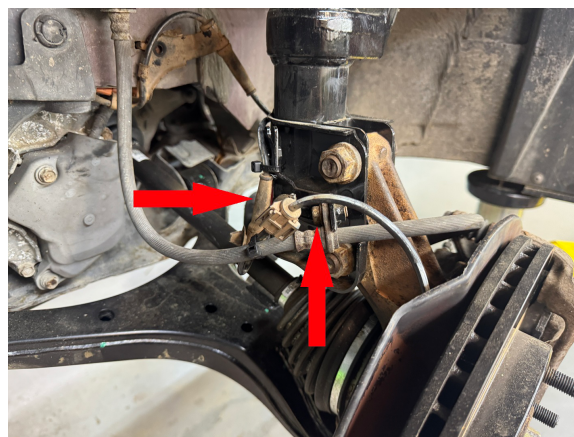

Step 27. Remove M16x62mm bolts connecting strut to knuckle.

Step 28. Remove castle nut and strike the steering arm with a heavy hammer to dislodge the tie rod end. Save hardware.

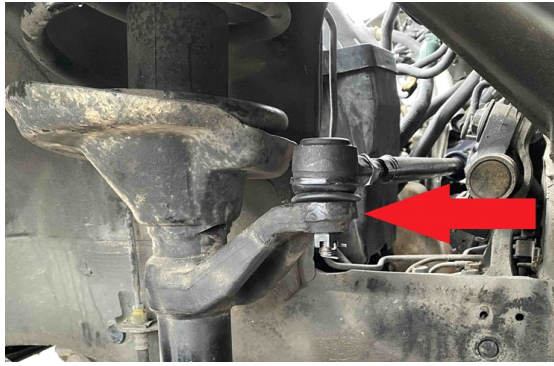

Step 29. Remove 14mm nuts at the top of the struts. Remove strut. Save hardware for reinstallation.

NOTE: Do not allow the hub to fall loose, as the axle may come out of the inner CV boot. Secure the hub with a length of wire or zip ties until step 10.

Step 30. Cut notch in pinch weld on top of frame rail as shown:

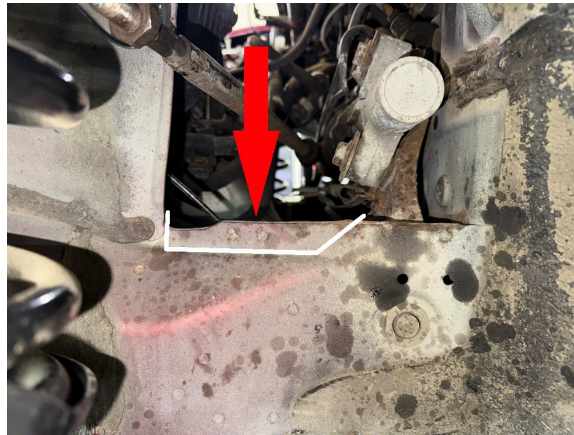

Step 31. Attach spacer marked "L" to top of DRIVER SIDE strut using original hardware.



Step 32. Install strut and spacer assembly into shock tower using 3 M10x25 bolts.

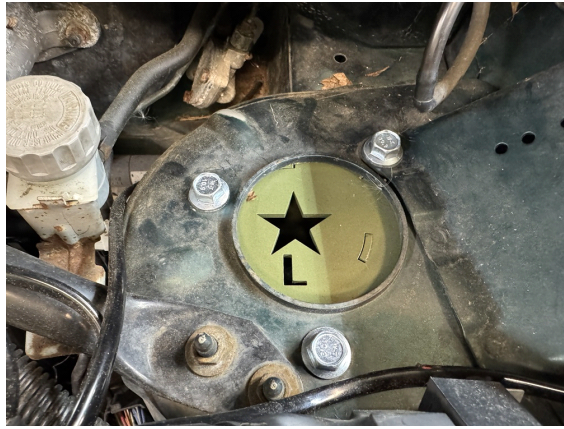

Step 33. Reinstall main strut bolts holding strut to knuckle.

Step 34. Once the main strut bolts are installed and tightened, remove the top bolt and replace it with the 16mm camber adjustment bolt. These bolts are eccentric and will need to be adjusted by an alignment shop. They should be tightened for now, until it is time for an alignment.

Step 35. Install brake line relocation bracket.

Step 36. Attach brake line to brake line bracket with supplied M8 bolt and nut. Secure ABS wiring (if applicable)

Step 37. Remove OEM outer tie rod ends on both sides. Leave stop nuts in place

Step 38. Using a 5/8" drill bit, drill out hole in strut as shown:



Step 39. Install the heim joint in place of the OEM tie rod end.

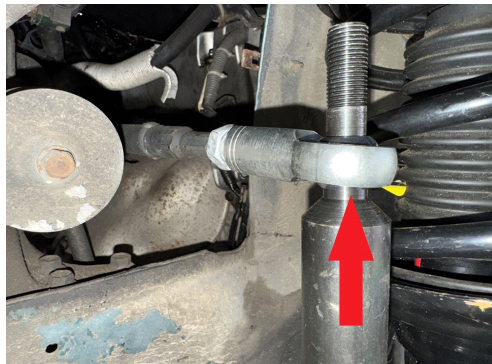

Step 40. Install collar and nut onto tie rod extension as shown in photo. Do not over-torque top nut.

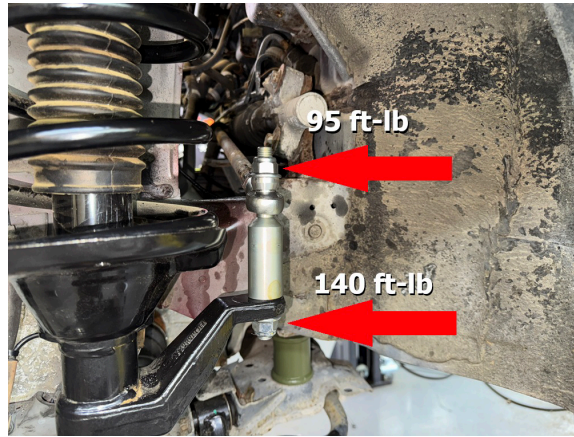

Step 41. Repeat spacer and tie rod end installation for passenger side.

Step 42. Double check the tie rod has clearance by turning the steering wheel lock to lock. If the tie rod hits the frame rail, you will need to do additional cutting on the frame rail. (see photo)



Step 43. Tighten all bolts. Be sure to double-check engine and transmission mounting bolts. Refer to factory service manual for remaining torque specifications. Mark bolts with paint pen that have been double checked.

Rear installation:

Step 1. With vehicle still on the ground, remove plastic panels in rear compartment to allow access to rear strut mounting bolts.



Step 2. Remove 2 M10 bolts on each side holding rear struts to body (see photo)



Step 3. Lift vehicle and support with jack stands.

Step 4. Remove wheels.

Step 5. Support rear subframe with floor jack.

Step 6. Remove 19mm bolt connecting rear strut to lower arm.

Warning: these bolts are prone to seizing inside the bushing. If the bolts seize, you will need to cut the bushings and replace them, or replace the strut.

Step 7. Remove bolts connecting upper control arm to rear hub, allowing assembly to drop enough to remove strut. Rear upper control arm will be replaced with an adjustable one. Take care not to put stress on rubber brake lines. (see photo)

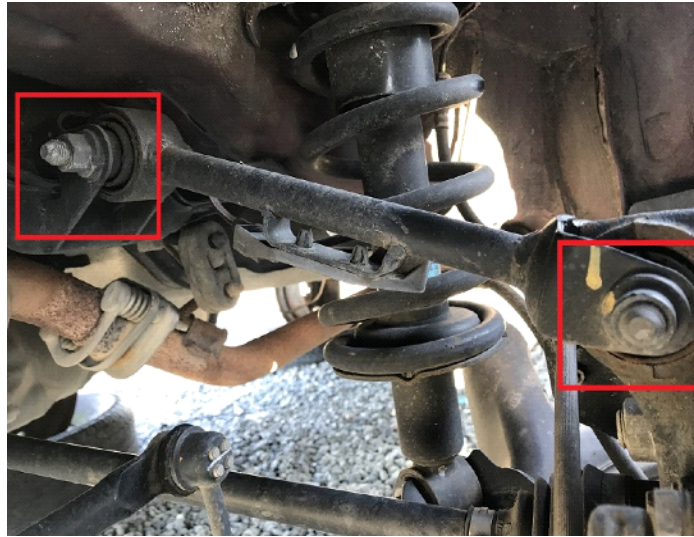

Step 8. Remove rear struts, save hardware for reinstallation.

Step 9. Remove 2 of the 4 17mm bolts holding the rear subframe to body and temporarily replace with M12x150 bolts

Step 10. Remove the other 2 17mm bolts. (leave 2 bolts in at all times to maintain alignment of subframe)

Step 11. Remove the 2 M6 bolts holding the charcoal canister to the body. (refer to photo)

For 2WD, skip to step 11

Step 12. Remove the 2 M10 bolts holding the rear differential bracket to the body. (refer to photo)

Step 13. Remove 4 M8 bolts holding driveshaft safety loops to body, set safety loops aside for reinstallation. (refer to photo)

Step 14. Remove 2 M8 bolts on each side holding rear brake lines to body (refer to photo for upper brake line bracket)

Step 15. Remove 2 M8 bolts beside rear trailing arms holding parking brake cables to body. (refer to photo)

Step 16. Loosen 2 17mm bolts in driver side rear trailing arm to frame.

Step 17. Carefully lower rear subframe about 3 inches.

For 2WD skip to step 18

Step 18. Remove 2 14mm bolts holding differential bracket to body, lower differential assembly (do not remove from vehicle)

Step 19. Place 2 1.25x3" spacers between differential and differential bracket. Install 2 M12x140 bolts. (see photo)



Step 20. Reinstall rear differential and bracket using original hardware

Step 21. Place 2 2.5x3" M12 spacers between subframe and body, install 2 M12x150 bolts.

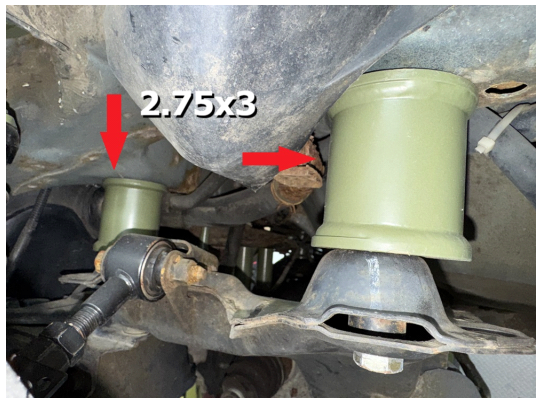

Step 22. Repeat step 17 for remaining 2 subframe bolts.

Step 23. Place 2 0.5x3" M6 spacers and install M6x100 bolts in charcoal canister (see photo)



Step 24. Remove M12 bolts holding trailing arms to body.

Step 25. Place trailing arm drop bracket between trailing arm and body, install 2 M12x150 bolts. (see photo below)



Step 26. Install parking brake cable bracket with M8 bolt (see photo)

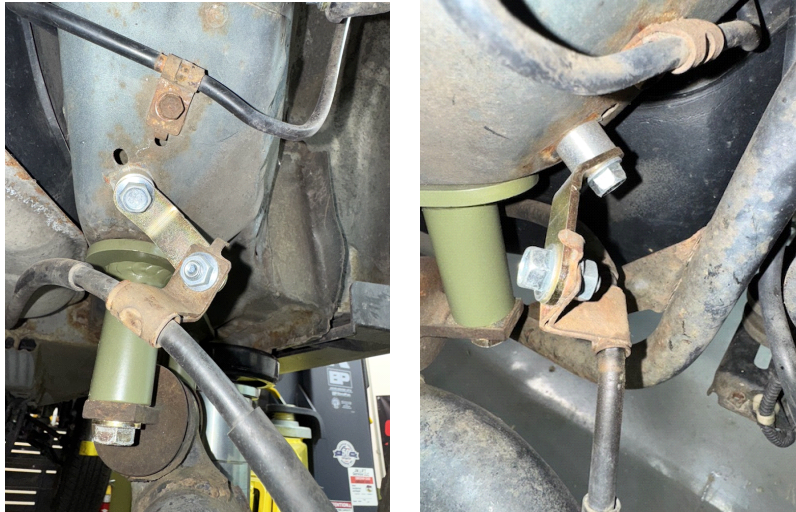

Step 27. Locate mount for rear brake line (lower) and install brake line bracket (lower) with M8 bolt and nut. (see photo)



Step 28. Install upper brake line drop bracket (see photo)

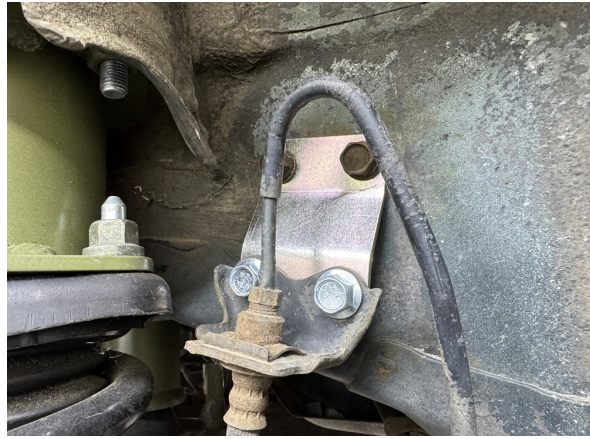

Step 29. Remove 2 M10 bolts in driveshaft carrier bearing.

TIP: It is helpful to have a jackstand under the driveshaft to help support the weight.

Step 30. Place 2 1x3" spacers between driveshaft carrier bearing and body. Secure with M10x100 bolts. (see photo)

Step 31. Place 2 0.75x1.5" spacers between driveshaft safety loops and body. Secure with M8x70 bolts (see photo)



Step 32. Attach spacers onto struts using original hardware.



Step 33. Reinstall strut in reverse order of removal.

Step 34. Using a floor jack, lift up on lower control arm until upper control arm lines up with wheel hub.

Step 35. Install new adjustable rear upper control arm.

Step 36. Remove 2 rubber hangers on exhaust mid-pipe

Step 37 Install 2 extended exhaust hangers (see photo)



Step 38. Remove 2 rubber hangers on muffler.

Step 39. Install 2 extended exhaust hangers on muffler (see photo)



Step 40. Reinstall wheels and set vehicle on the ground before tightening lower control arm bolts. It may be necessary to roll vehicle back and forth a few times to get the suspension to its resting point.

Step 41. Using a torque wrench, double check all bolts (refer to factory service manual for torque specifications) and mark bolts with paint pen that have been double checked.

Step 42. Get a professional 4 wheel alignment.

Step 43. Find some trails!

Note: Installing a lift kit will change the suspension geometry and will require a 4 wheel alignment.

Warning: Failure to follow the procedures in these

installation instructions may result in unsafe handling characteristics, damage to vehicle, or loss of control.

For tech support, please call 1-844- HRG LIFT (474-5438) from 8-6PM EST Mon-Fri or email us 24/7 at support@hrgoffroad.com.

This product is intended for off-road use only!!

Copyright HRG Offroad 2025

2002-2006 CR-V 6 INCH BEAST KIT SUBFRAME DIAGRAM (C) HRG OFFROAD 2022

- 2.5x3 M12 spacers
- 2.5x3 M14 spacers
- 2.5x1.5 M10 spacers
- 1.25x3 M12 spacers

