



2003-2011 Element 3 inch (76mm) lift kit installation guide

Professional installation is recommended.

IMPORTANT!

Lifting and modifying the suspension on your vehicle may result in drive line vibrations, damaged bushings, erratic handling characteristics, and shortened suspension component life. HRG Offroad recommends the following:

- Checking and/or replacing worn drive axles with new parts, not remanufactured.
- Checking and/or replacing all worn factory rubber bushings with urethane bushings, such as Prothane.
- Checking and/or replacing worn shock absorbers and bump stops.
- Performing a 4-wheel alignment after working on suspension components.

Lift kits may not be legal for use on public highways in your area. Please check local laws before installing!!

WARNING!

Lifted vehicles are more prone to rolling over.

Some HRG Offroad products are designed to improve off-road capabilities. Modifying the suspension of your vehicle may result in handling characteristics that are different from a factory equipped vehicle. Extreme care must be used to prevent a rollover or loss of control. Always operate your modified vehicle at a reduced speed to ensure your ability to maintain control under all driving conditions. Driving your vehicle in an unsafe manner may result in serious injury or death. HRG Offroad lift kits are designed and tested to work together. HRG Offroad does not recommend combining this lift kit with any other type of suspension or body lift. Always wear your seat belt.

Recommended tire/wheel sizes:

Stock 205/70/15 (26.3") or 215/65/16 (26.4")

15" wheels:

205/75/15 (27.0")

225/70/15 (27.4")

215/75/15 (27.7")

225/75/15 (28.2")

235/75/15 (28.8")

30x9.50R15 (30.0")* May require fender modification!

16" wheels

215/70/16 (27.8")

235/70/16 (28.9")

225/75/16 (29.2")

235/75/16 (29.8")

255/70/16 (30.0")* May require fender modification!

Be sure to check fitment prior to installation! These sizes are only suggestions. HRG is not responsible for improperly fitted wheels/tires.

Included in the kit:

2 2.5" spacers (front) 5210
2 2.0" spacers (rear) 5252
10 M10x25mm grade 10.9 bolts (front and rear spacers)
2 16mm offset camber adjustment bolts (optional)
2 adjustable rear upper control arms (optional)
2 1" brake line extension brackets (rear)
4 1.25x 1" M12 spacers (rear lower arm)
4 1.25x1" M12 spacers (rear subframe)
2 1.25x1" M12 spacers (engine/transmission)
3 1.25x1" M14 spacers (engine/transmission)
4 1.25x1" M14 spacers (front subframe)
2 2.75x1 M10 spacers (rear differential, **4WD kit only**)
2 M10x120 bolts (rear differential, **4WD kit only**)
2 1x1" M10 spacers (driveshaft carrier bearing, **4WD kit only**)
2 M10x50mm bolts (driveshaft carrier bearing, **4WD kit only**)
2 M8x40mm bolts (driveshaft safety loops, **4WD kit only**)
2 0.75x1" M8 spacers (driveshaft safety loops, **4WD kit only**)
4 M14x150mm bolts (front subframe)
1 M12x70mm bolt (engine)
1 M12x60mm bolt (transmission)
4 M12x100mm bolts (rear subframe)
4 M12x100mm bolts (rear lower arm)
2 M6x40mm bolts/1" spacers (charcoal canister)
2 exhaust hanger extensions

Tools required:

Floor Jack, lug wrench, metric socket set up to 21mm, metric wrench set up to 19mm, cutoff wheel, impact wrench, torque wrench, needle-nose pliers, heavy hammer, and paint pen.

Note to installer: All bolts removed to install subframe kit will be replaced with longer bolts. Some OEM hardware will be reused.

Approximate installation time: 5-6 hours.

Skill level: Moderate

Front installation:

Step 1. Disconnect and remove the battery.

Step 2. Support engine/transmission with floor jack, taking care not to dent oil pan.

Step 3. Remove factory air box (if applicable) to gain access to transmission mount.

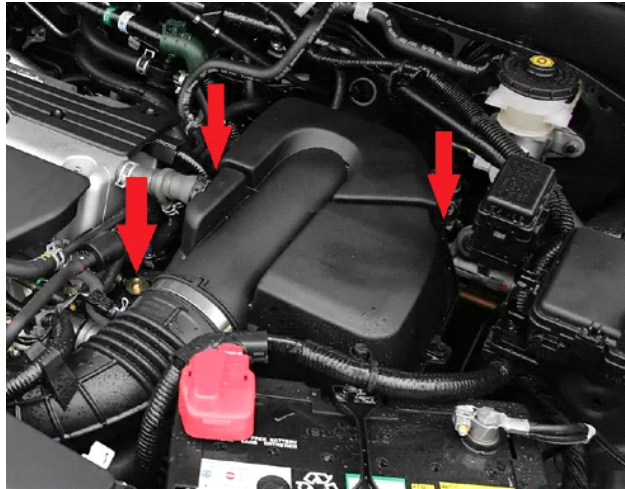

Step 4. Remove 2 M12 nuts and one M12x35 bolt holding the transmission bracket to the transmission. Remove driver side transmission bracket, discard M12x35 bolt. Save 2 M12 nuts.

Step 5. Slide 2 1.25x1-M14 spacers over the studs in the transmission and place one 1.25x1-M12 spacer over the remaining hole. (See diagram.)

Step 6. Reinstall the transmission bracket and use the M12x60 bolt provided in place of the M12x35. (See diagram.) It may be necessary to leave the hardware loose at this time until the subframe spacers are installed.

Step 7. Remove M12 nut and M12x45 bolt holding the engine bracket to the body and the engine. Remove passenger side engine bracket, discard M12x45 bolt. Save M12 nut.

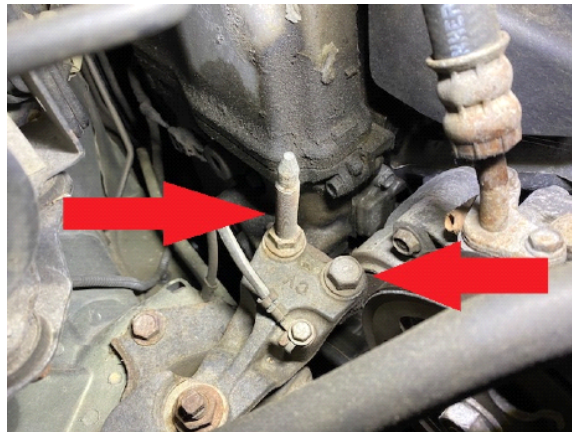

Step 8 Slide one 1.25x1-M14 spacer over the stud in the engine and place one 1.25x1-M12 spacer over the remaining hole. (See diagram.)

Step 9. Reinstall engine bracket and use provided M12x70 bolt in place of the M12x45. (See diagram.) It may be necessary to leave the hardware loose at this time until the subframe spacers are installed.

**2003-2011 ELEMENT
1" ENGINE SPACER DIAGRAM
(C)HRG OFFROAD 2022**

- 1.25x1 M14 spacer
- 1.25x1 M12 spacer

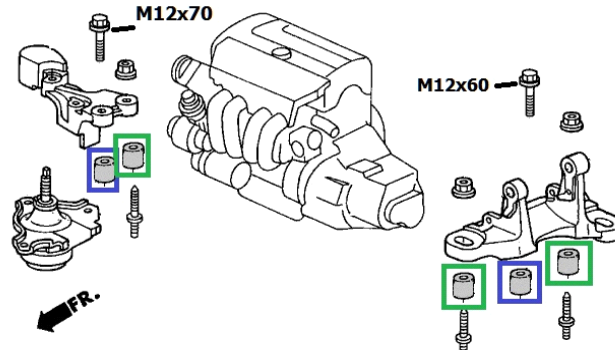

Step 10. Jack up vehicle and support with jack stands.

Step 11. Using a floor jack or screw jack, support engine cradle.

Step 12. Remove 2 of the 4 M14x115 bolts and loosen the other 2 M14x115 bolts holding the sub frame to the body. **DO NOT remove all 4 bolts at once.**

NOTE: This is to ensure the subframe stays lined up with the body.

Step 13. Carefully lower the subframe enough to slide 2 1.25x1-M14 spacers in between the subframe and the body. (See diagram.)

Step 14. Discard the 2 M14x115 bolts and replace with M14x150 bolts provided in the kit.

Step 15. Repeat step 13-14 for the remaining 2 bolts.

FOR STEPS 16-19 PLEASE SEE DIAGRAM ON LAST PAGE OF INSTRUCTIONS.

Step 16. Locate driveshaft safety loops surrounding drive shaft and remove one of the 2 bolts holding them to the body.

Step 17. Install 1 0.75x1 spacer and M8x40 bolt in each loop, allowing it to drop enough to clear the drive shaft once it is lowered.

Step 18. Locate carrier bearing (center support for driveshaft), and remove 2 14mm bolts, allowing it to drop. Temporarily support driveshaft using a jackstand.

Step 19. Install 2 1x1 M10 spacers between carrier bearing and body, secure with 2 M10x50 bolts.

Front spacer installation:

Step 1. Lift vehicle and support with jack stands.

Step 2. Remove wheels.

Step 3. Remove ABS wire and brake line from driver side strut.

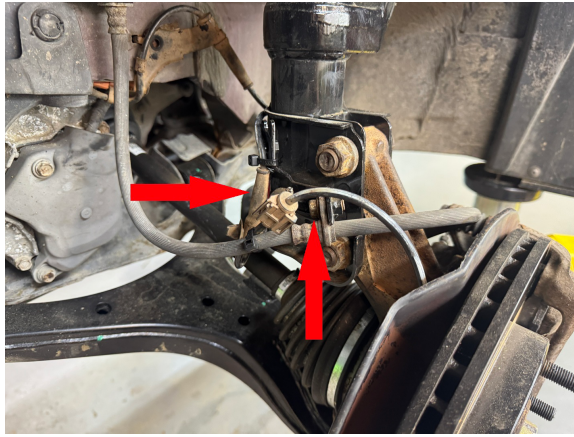

Step 4. Remove 21mm bolts connecting strut to knuckle.

Step 5. Remove the castle nut and strike the steering arm with a heavy hammer to dislodge the tie rod end. Save hardware.



Step 6. Remove 14mm nuts at the top of the strut connecting strut to strut tower. Remove strut. Save hardware for reinstallation.

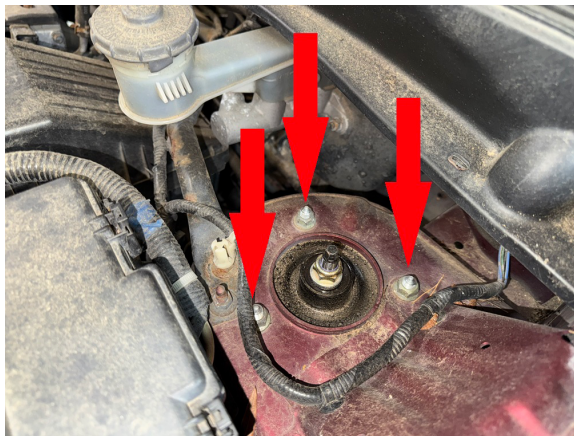

NOTE: Do not allow the wheel hub to fall as the axle may come out of the inner CV boot.

Step 7. Install spacer marked "L" on driver side strut using original hardware as shown:



Step 8. Trim pinch weld on top of frame just below tie rod end for added clearance (3" kit only). See photo. Touch up bare metal with spray paint or undercoating for protection.

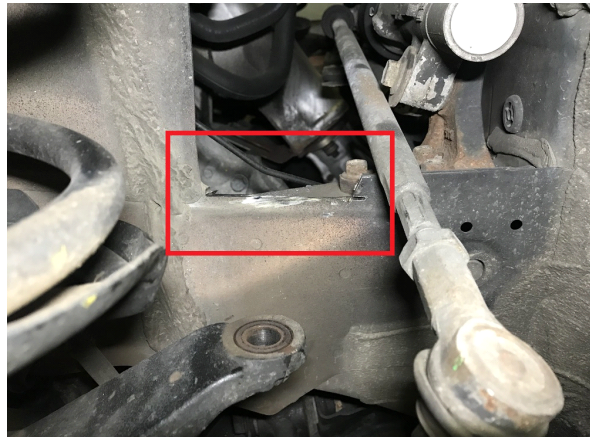

Step 9. Reinstall strut, using M10x25 bolts through the top and into the spacer. Be sure "L" spacer is installed on driver side.

Step 10. Install offset camber bolts (optional). See separate instructions.

Step 11. Reinstall steering tie rod. Do not forget the cotter pin!

Step 12. Repeat spacer installation process for passenger side.

Step 13. Tighten all bolts, double check engine and transmission mounting bolts.

Step 14: Use torque wrench to double check all bolts. Refer to factory service manual for torque specifications. Mark bolts with paint pen that have been double checked.

Step 15. Reinstall air box.

Step 16. Reinstall battery.

Rear installation:

Step 1. Jack up vehicle and support with jack stands.

Step 2. Remove wheels.

Step 3. Support rear subframe with floor jack.

For steps 4-9 please refer to diagram on back page.

Step 4. Loosen 4 17mm bolts holding rear subframe to chassis but do not remove. Using the jack, carefully lower the rear subframe by about one inch.

Step 5. Install 4 1.25x1 M12 spacers using M12x100 bolts. Install new bolts one by one to maintain alignment of subframe.

Step 6. Remove M6x16 bolts retaining charcoal canister to body. Install 2 0.5x1" spacers and M6x40 bolts keeping charcoal canister attached to rear crossmember.

If 2wd, skip to step 8.

Step 7a. (4WD only) Support rear differential with floor jack.

Step 7b. Remove 2 bolts connecting rear differential support bracket to body. (See diagram.)

Step 7c. Install 2 2.75x1 M10 spacers between differential support bracket and body. Install M10x120 bolts.

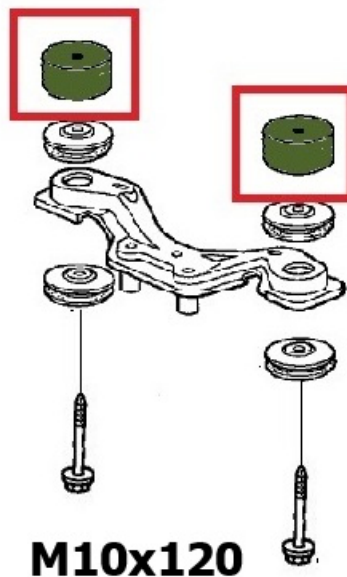

Step 8. Loosen 2 17mm bolts in driver side rear trailing arm to frame.

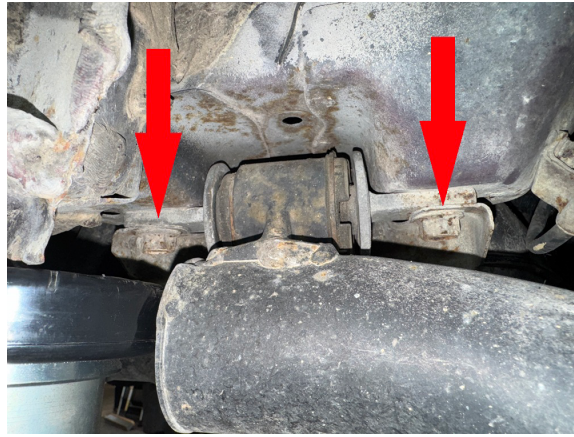

Step 9. Install 2 1.25x1" M12 spacers and M12x100 bolts **one at a time** in rear trailing arm to frame.

TIP: Do not remove both trailing arm bolts at the same time as it can be difficult to get the bolts to line up.

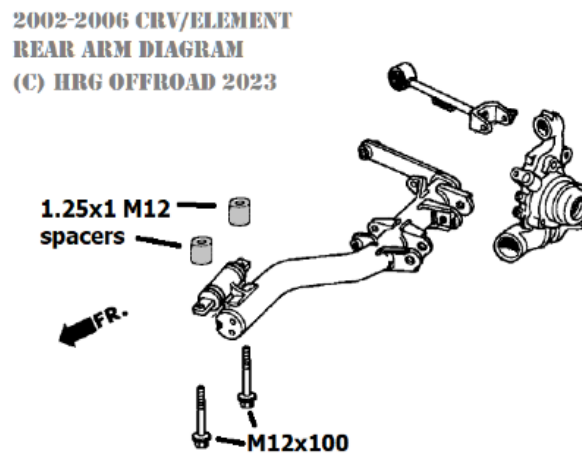

Step 10. Repeat trailing arm spacer installation for passenger side.

Step 11. Remove 19mm bolt connecting rear strut to lower arm.

Note: These bolts are prone to seizing inside the bushing. If the bolts seize, you will need to cut the bushings and replace them or replace the strut.



Step 12. Loosen bolts on rear lower control arm and disconnect rear sway bar to allow suspension to drop.

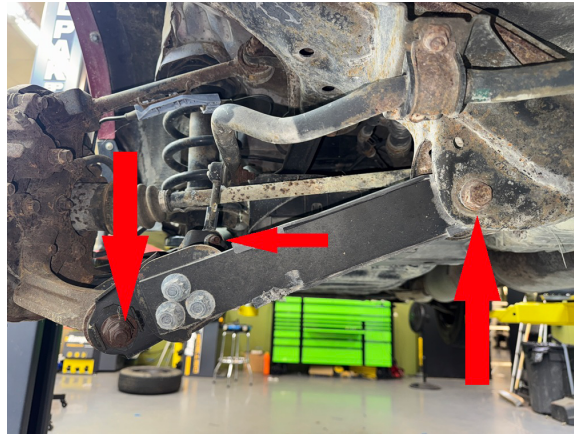

Step 13. Remove interior trim panels to gain access to upper strut mounting bolts. (See photo.)



Step 14. Remove 2 14mm nuts at the top of the strut connecting the strut to the body, remove strut. Save hardware for reinstallation.

Step 15. Attach spacers onto struts using original hardware. (See diagram.)

**2002-06 CR-V/ELEMENT REAR
SPACER INSTALLATION
DIAGRAM
(C) HRG OFFROAD 2022**

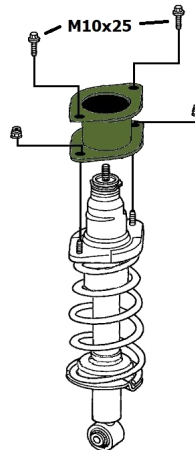

Step 16. Reinstall strut in reverse order of removal.

Step 17. Install adjustable upper control arm in place of OEM arm. Adjust length to be approximately ¼" longer than the OEM arm. An alignment technician will need to make final adjustments!

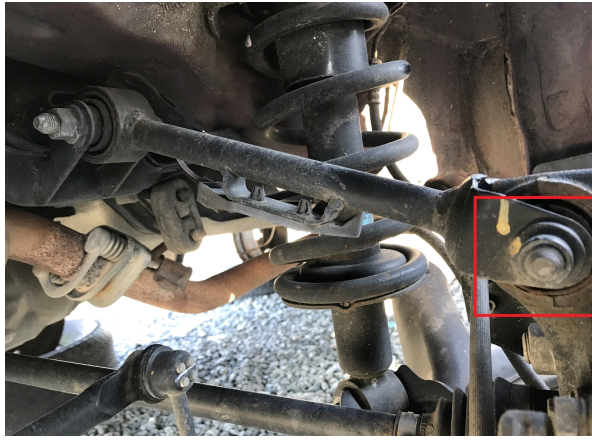

Step 18. Using a floor jack, lift the rear lower control arm until upper control arm lines up with wheel hub.

NOTE: DO NOT TIGHTEN REAR SUSPENSION BOLTS AT THIS TIME. LEAVE BOLTS SLIGHTLY LOOSE UNTIL THERE IS WEIGHT ON THE SUSPENSION!

Step 19. Install extended exhaust hangers to appropriately lower exhaust system to prevent contact with rear axle.

Step 20. Reinstall wheels and lower vehicle.

Step 21. **At this time tighten all rear suspension bolts. This step is important for proper ride height and bushing life.**

Step 22 Using a torque wrench, double check all bolts (refer to factory service manual for torque specifications) and mark bolts with paint pen that have been double checked.

Step 23. Get a professional 4-wheel alignment.

NOTE: If vehicle seems extremely high in back, roll the vehicle back and forth to settle the suspension. The suspension will settle more once you drive it. You will also notice a difference after the alignment has been done. Due to the vast number of different aftermarket struts and springs, your results may vary.

Note: Installing a lift kit will change the suspension geometry and will require a 4 wheel alignment.

Warning: Failure to follow the procedures in these installation instructions may result in unsafe handling characteristics, damage to vehicle, or loss of control.

For tech support, please call 1-844- HRG LIFT (474-5438) from 8-4:30 PM EST Mon-Thu 8-3:30 PM Fri or email us 24/7 at support@hrgoffroad.com.

This product is intended for off-road use only!!

Copyright HRG Offroad 2025

**2002-2006 CR-V/2003-2011 ELEMENT
SUBFRAME KIT INSTALLATION
DIAGRAM
(C) HRG OFFROAD 2022**

- 1.25x1 M12 spacer
- 1.25x1 M14 spacer
- 2.75x1 M10 spacer

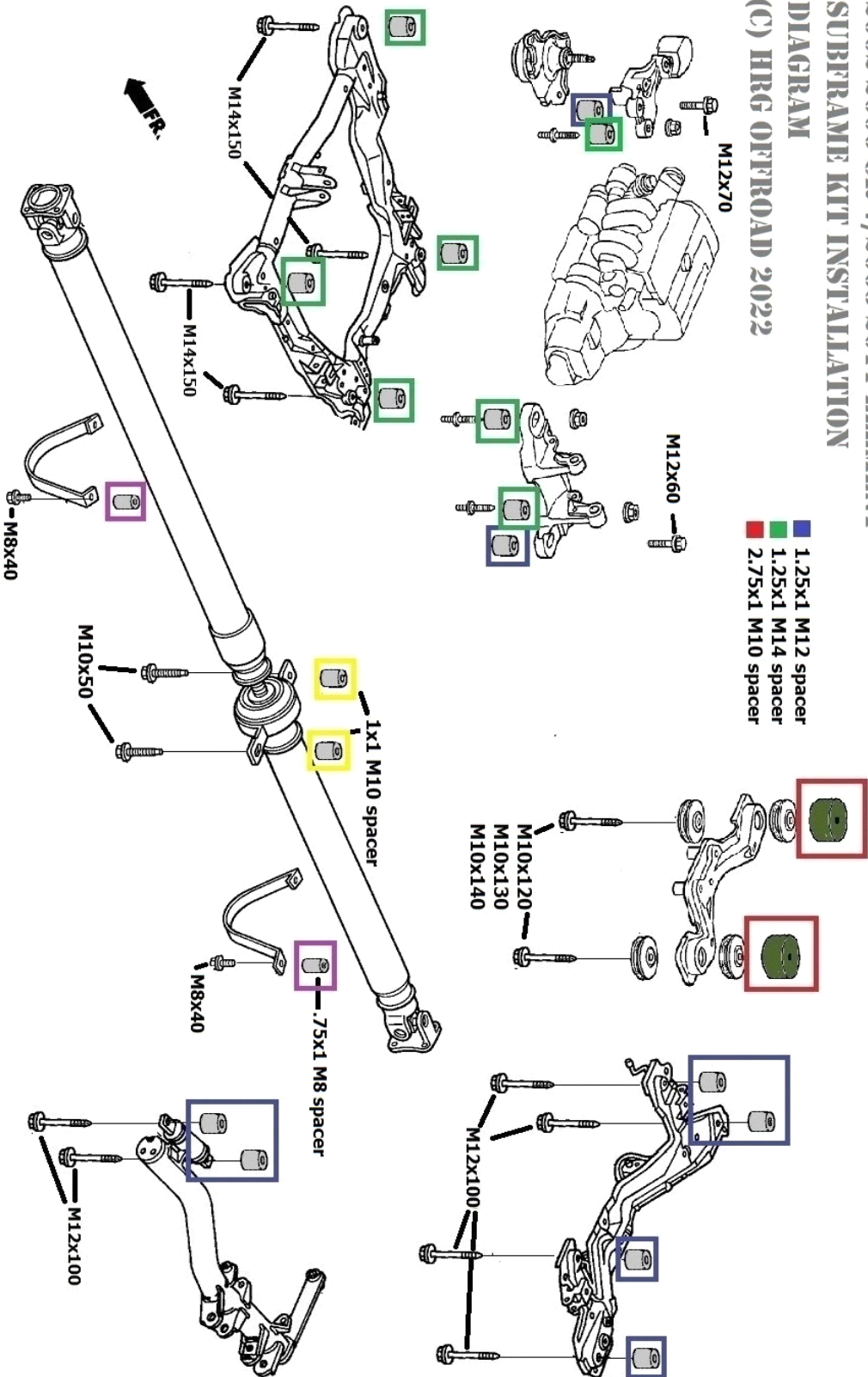

CAMBER BOLT INSTRUCTIONS

WARNING: THE NUTS ON THESE BOLTS HAVE A SELF-LOCKING FEATURE. THE NUT WILL STOP TURNING ONCE YOU REACH THIS POINT AND YOU CAN NO LONGER TURN IT BY HAND. YOU MUST USE A TORQUE WRENCH TO TIGHTEN THEM TO THE SPECIFICATIONS LISTED BELOW. ONCE TORQUED, THE NUT WILL LOCK ONTO THE BOLT.

For camber changes greater than 1 degree, it will be necessary to install camber bolts in upper and lower bolt locations in the strut flange.

1. Check and document initial alignment readings
2. Raise vehicle and remove tire/wheel assembly
3. Remove upper strut bolt (do not loosen lower strut bolt)
4. Install slotted washer on bolt.
5. Insert camber bolt with washer through the strut/spindle assembly in the same direction the OEM bolt came out. Snug lock nut but do not tighten
6. Loosen lower strut bolt. On models with splined spindle bolt, drive bolt out until splines are free from flange.
7. Reinstall tire/wheel assembly and alignment equipment or simply use Camber Kwik gauge. Rotate camber bolt until desired camber is achieved.
8. Tighten all bolts and torque but **DO NOT EXCEED TORQUE SPECIFICATIONS.**
9. Proceed with rest of alignment and road test vehicle.

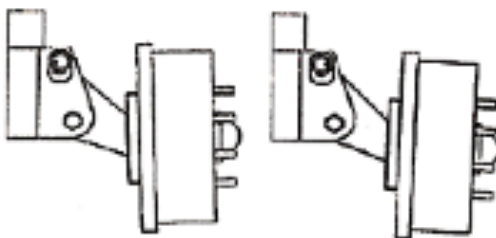
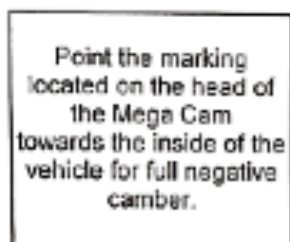
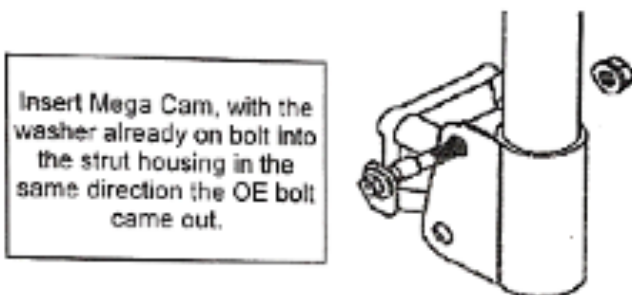

Part #	Max. Torque	
1001	60 ft. lbs.	12mm Ultra Cam
1002	100 ft. lbs.	14mm Ultra Cam
1003	100 ft. lbs.	15mm Ultra Cam
1004	150 ft. lbs.	16mm Ultra Cam
1005	150 ft. lbs.	17mm Ultra Cam