



CIVIC

2016-2021 Honda Civic 1.5" lift kit installation guide

Professional installation is recommended

FOR OFF-ROAD USE ONLY!

IMPORTANT!

Lifting and modifying the suspension on your vehicle may result in drive line vibrations, damaged bushings, erratic handling characteristics, and shortened suspension component life. HRG Offroad recommends the following:

- Checking and/or replacing worn drive axles with new parts, not remanufactured.
- Checking and/or replacing all worn factory rubber bushings with urethane bushings, such as Prothane.
- Checking and/or replacing worn shock absorbers and bump stops.
- Performing a 4-wheel alignment after working on suspension components.

Lift kits may not be legal for use on public highways in your area. Please check local laws before installing!!

WARNING!

Lifted vehicles are more prone to rolling over.

Some HRG Offroad products are designed to improve off-road capabilities. Modifying the suspension of your vehicle may result in handling characteristics that are different from a factory equipped vehicle. Extreme care must be used to prevent a rollover or loss of control. Always operate your modified vehicle at a reduced speed to ensure your ability to maintain control under all driving conditions. Driving your vehicle in an unsafe manner may result in serious injury or death. HRG Offroad lift kits are designed and tested to work together. HRG Offroad does not recommend combining this lift kit with any other type of suspension or body lift. Always wear your seat belt.

Recommended tire/wheel sizes:

Stock size: 235/65/17 (LX); 235/60/18 (EX, EX-L); or 235/55/19 (Touring)

For OEM 17" wheel:

245/65/17

245/70/17

255/70/17*

For OEM 18" wheel:

245/60/18

245/65/18

255/65/18*

17" aftermarket wheel: 17x8 +40

18" aftermarket wheel: 18x8 +40

For OEM 19" wheel:

245/55/19

255/55/19*

****Be sure to check fitment prior to installation! These sizes are only suggestions. HRG is not responsible for improperly***

fitted wheels/tires

Included in the kit:

- 2 1.5" front spacers 5303
- 6 M10 nuts (Front lift spacers)
- 2 1" rear spacers 5226
- 2 1.5" rear shock extensions
- 2 Replacement front sway bar end links
- 6 1.25x1 M12 spacers (rear subframe)
- 2 M12x60 (rear subframe)
- 4 M12x100 (rear subframe)
- 4 1.25x1 M14 spacers (Trailing arm spacers)
- 4 M14x80 bolts (Trailing arm bolts)
- 4 M8x70 bolts (Rear shock extensions)
- 2 1 inch brake line relocation brackets (rear brake lines)

TOOLS REQUIRED: Floor jack, lug wrench, metric socket set to 21mm, 36mm axle socket, metric wrench set to 19mm, impact wrench, pliers, heavy hammer, 4-foot pry bar, screwdriver, plastic cutting tool, torque wrench and paint pen.

Installation time: Approximately 5-6 hours

Skill level: Moderate

FRONT INSTALLATION:

Step 1. Lift vehicle and support with jack stands.

Step 2. Remove wheels.

Step 3. Remove nuts holding driver side sway bar link. Remove sway bar link.

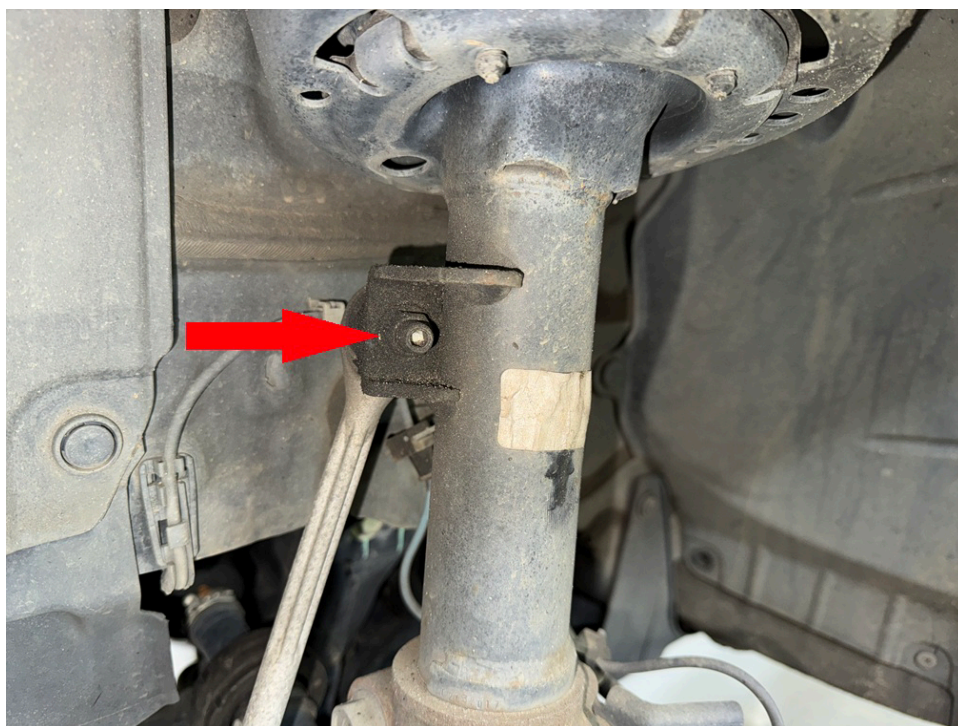

Step 4. Remove 12mm bolt holding brake line to strut and unclip ABS wires from knuckle.

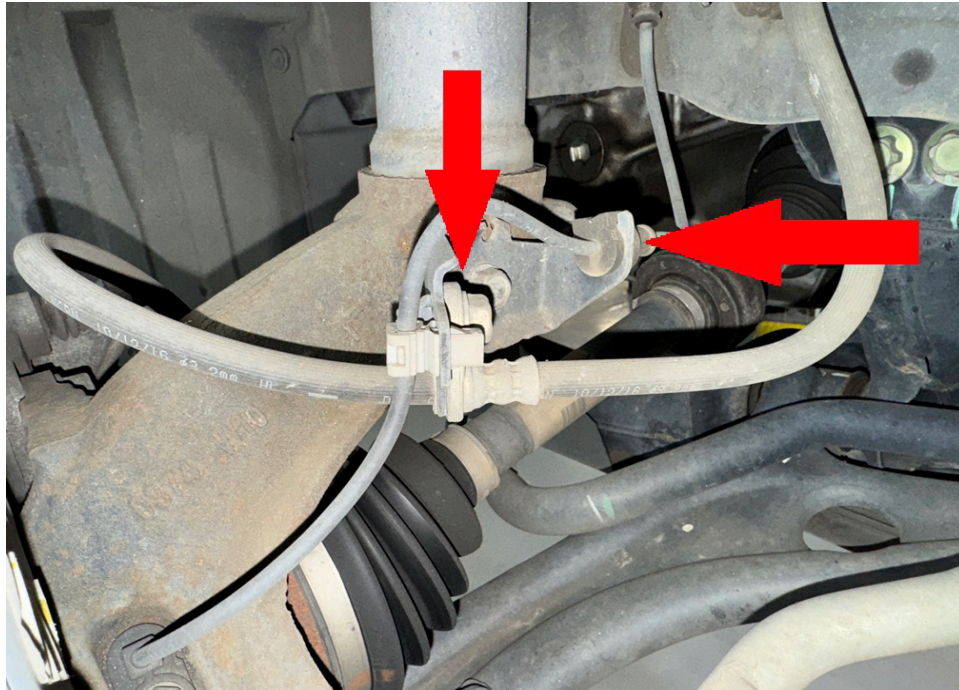

Step 5. Remove wheel sensor from knuckle.

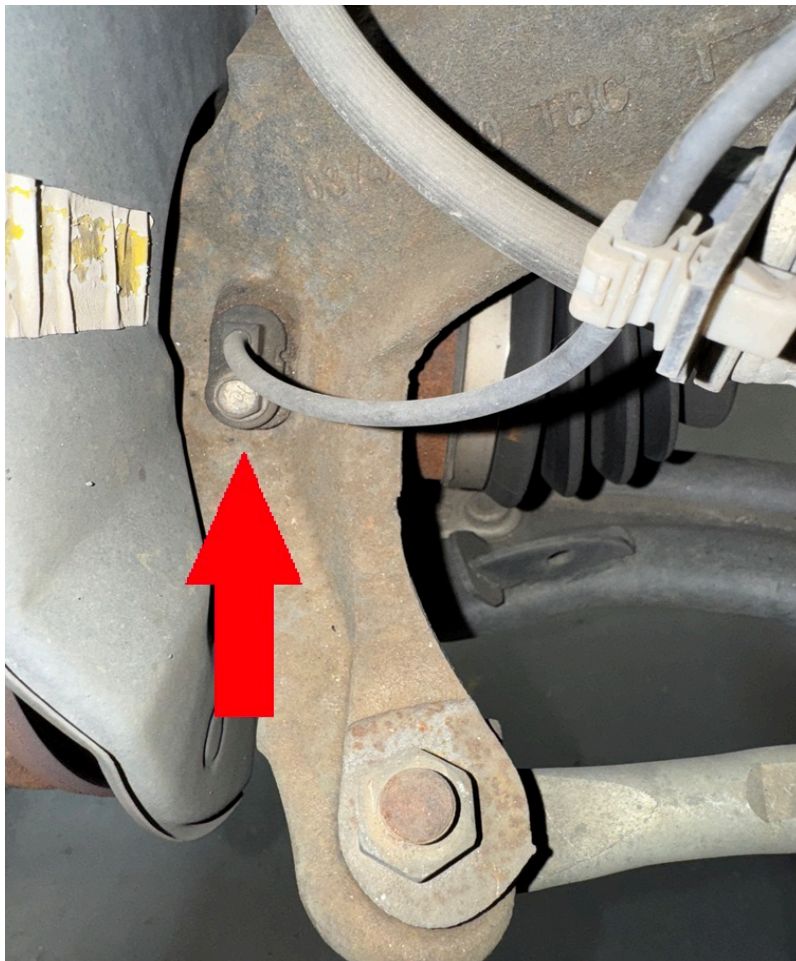

Step 6. Remove nut and strike knuckle to release tie rod end.



Step 7. Remove 2 17mm bolts holding brake caliper to wheel hub, suspend brake caliper to prevent stress on the flexible brake lines.

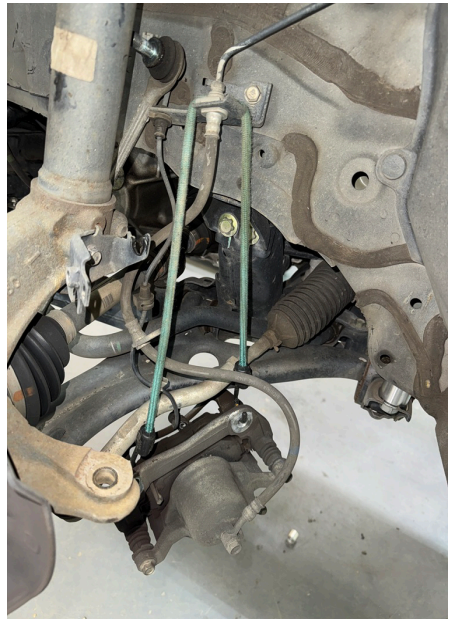
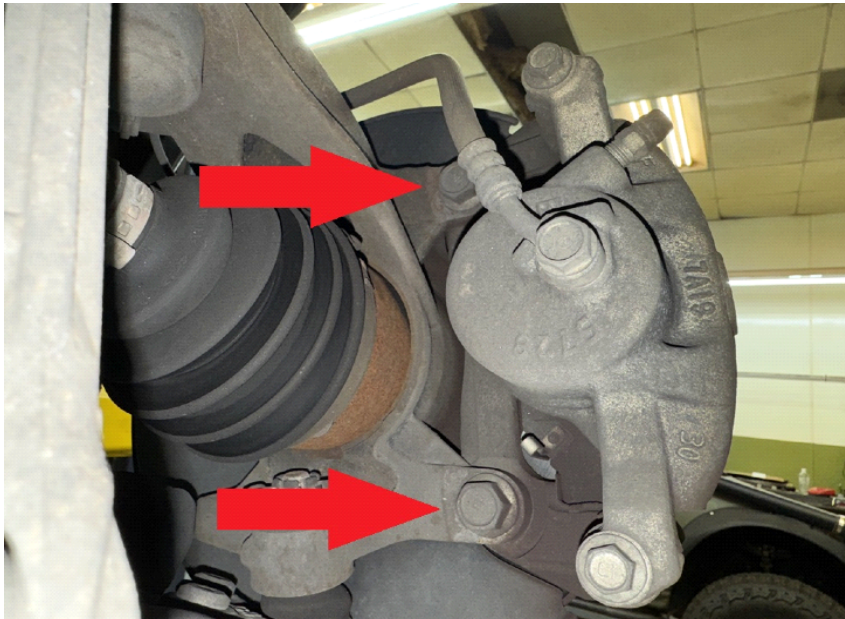

Step 8. Remove 3 17mm nuts holding lower ball joint to hub.

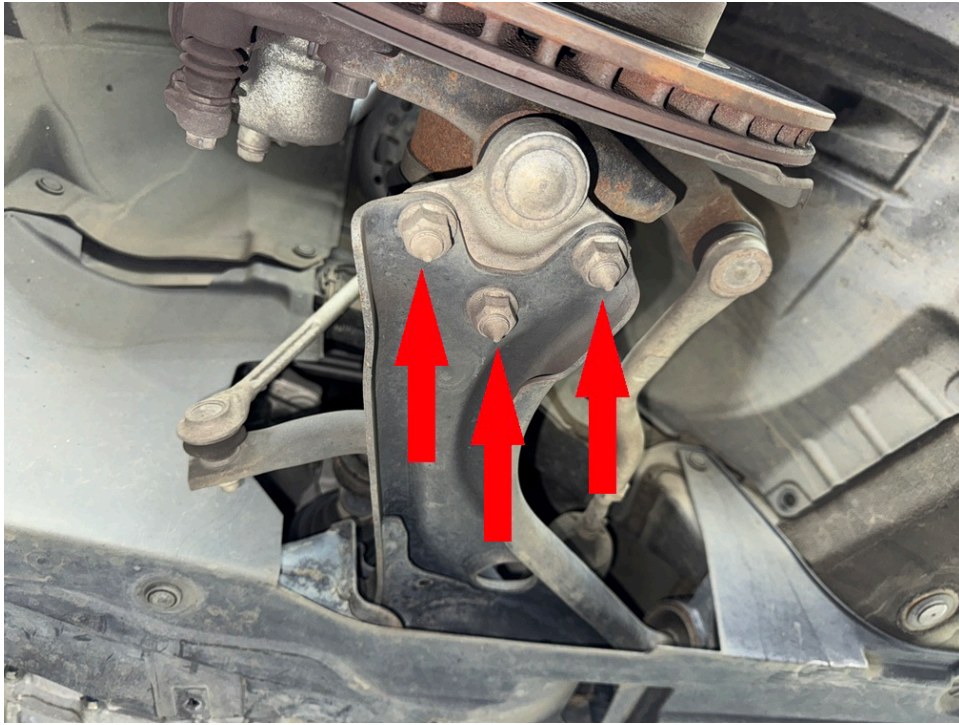

Step 9. Remove brake rotor, remove axle nut and slide axle out.

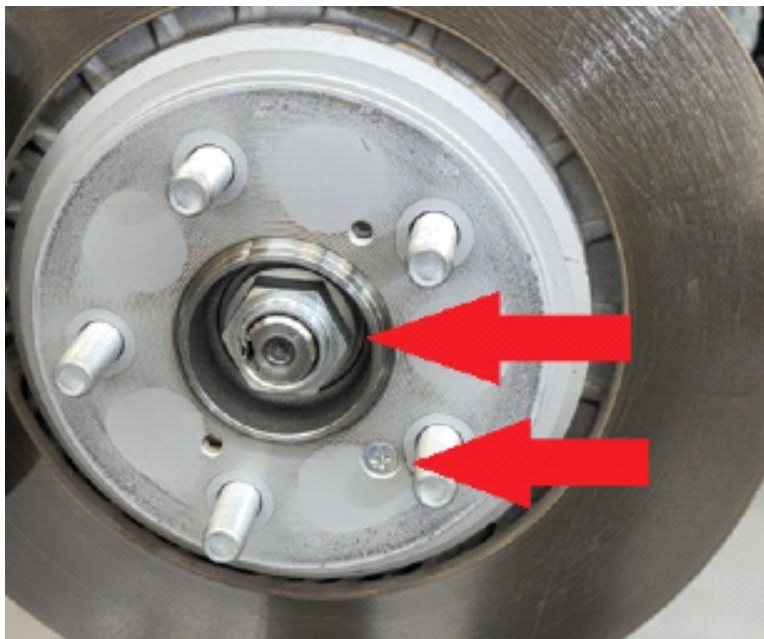

Step 10. Remove nuts from shock tower on driver side. Have a helper remove the strut and knuckle assembly.

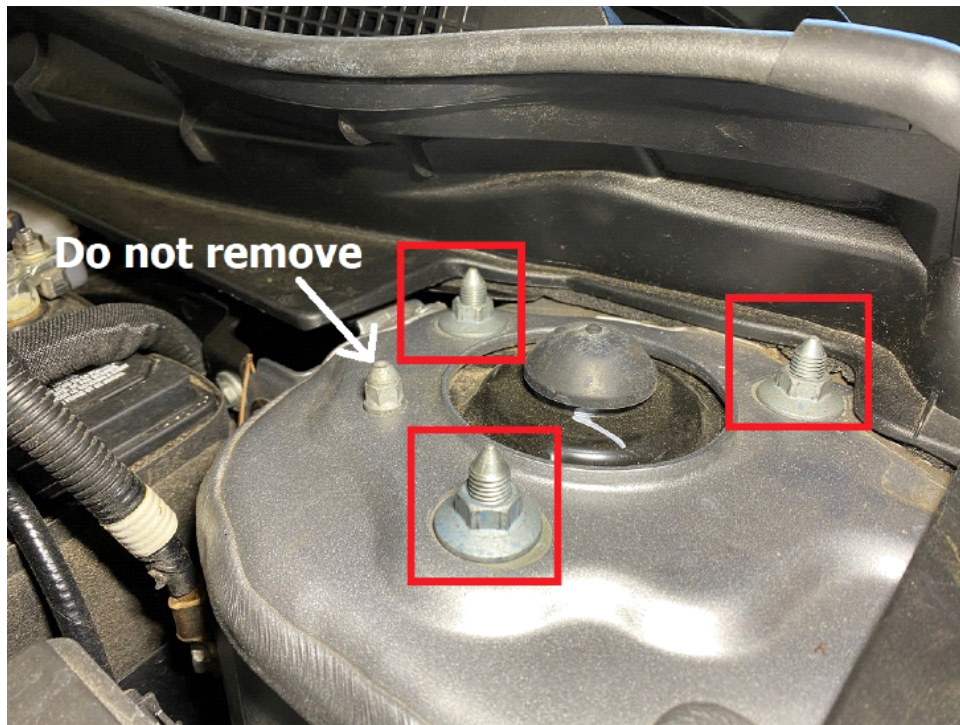

Step 11. Place strut spacer on top of strut and secure with hardware provided in the kit.



Step 12. Lift strut/spacer assembly through original mounting holes in strut tower. Secure strut with OEM hardware. Torque nuts to 33 ft-lb.



Step 13. Slide axle back into hub assembly and thread nut on to axle shaft. Torque axle nut to 242 ft-lb.

Step 14. Using a large pry bar, line up the lower control arm with the hub assembly and reinstall 3 nuts. Torque nuts to 74 ft-lb.

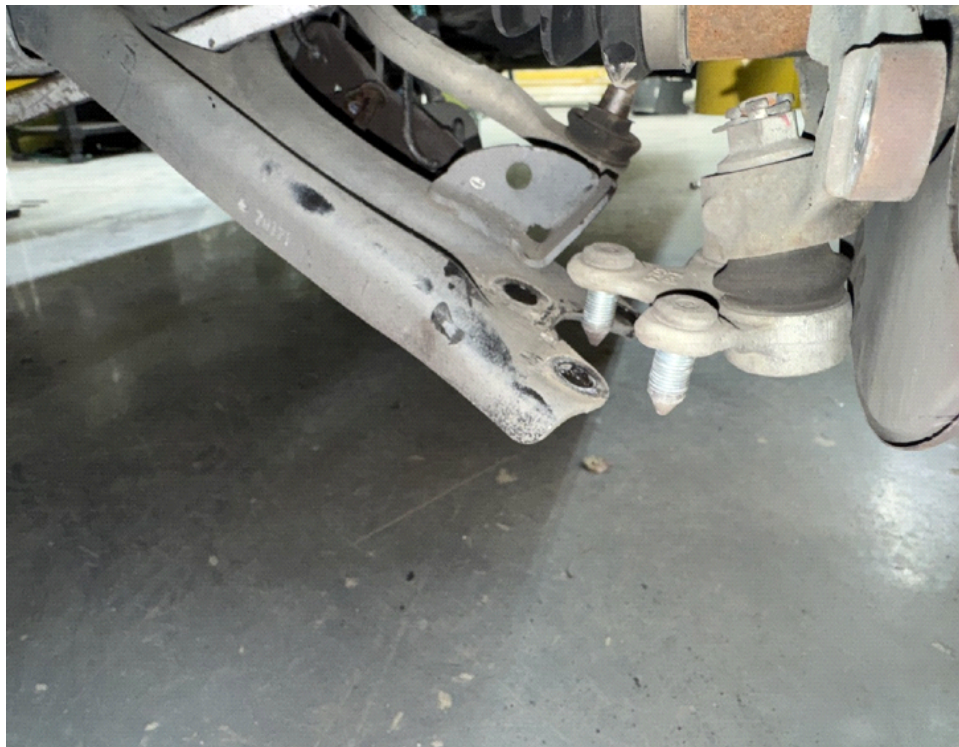

Step 15. Drill sway bar mounting holes for new sway bar link 1/2"

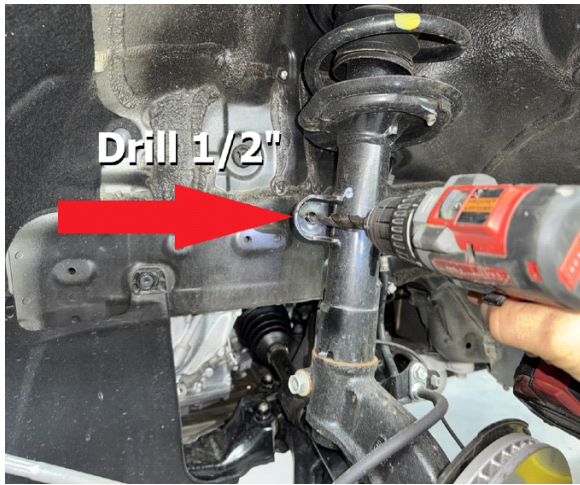

Step 16. Install new sway bar link. **Note: sway bar link holes will not line up until both sides are lifted.**

Step 17. Reinstall ABS wires and flexible brake lines. Torque brake line mounting bolt to 25 ft-lb

Step 18. Reinstall brake rotor and caliper. Torque caliper bolts to 80 ft-lb.

Step 19. Reinstall tie rod end.

Step 20. Double check all bolts.

Step 21. Reinstall wheel.

Step 22. Repeat installation process for passenger side.

Step 23. Attach sway bar links. Torque nuts to 56 ft-lb. **DO NOT OVERTORQUE!!**

REAR INSTALLATION:

Step 1. Lift vehicle and support with jack stands.

Step 2. Remove wheels.

Step 3. Support rear subframe with floor jack or screw jack.

Step 4. Remove the front 2 main subframe bolts starting with driver side front corner. Temporarily thread in a M12x60 bolt included in the kit in place of the original bolts. **DO NOT REMOVE ALL 6 SUBFRAME BOLTS AT THE SAME TIME!**

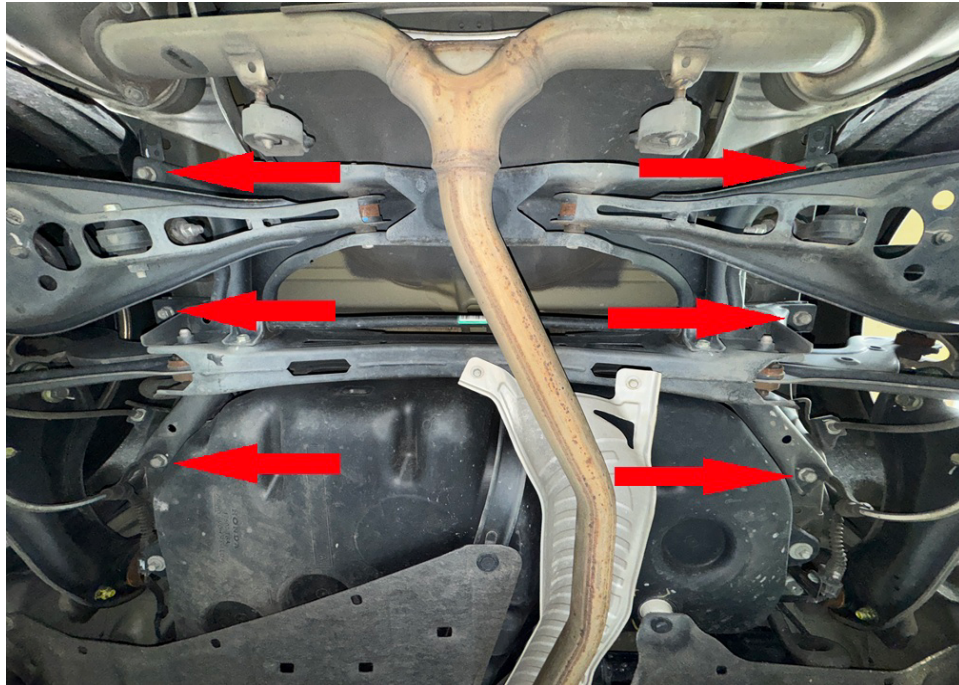

Step 5. Remove the remaining 4 main subframe bolts and temporarily install 4 M12x100 bolts as you go.

Step 6. Carefully lower subframe approximately 1 inch.

Step 7. Remove the front 2 bolts and place a 1.25x1 M12 spacer between the subframe and the body of the vehicle. Repeat this process on the passenger side.

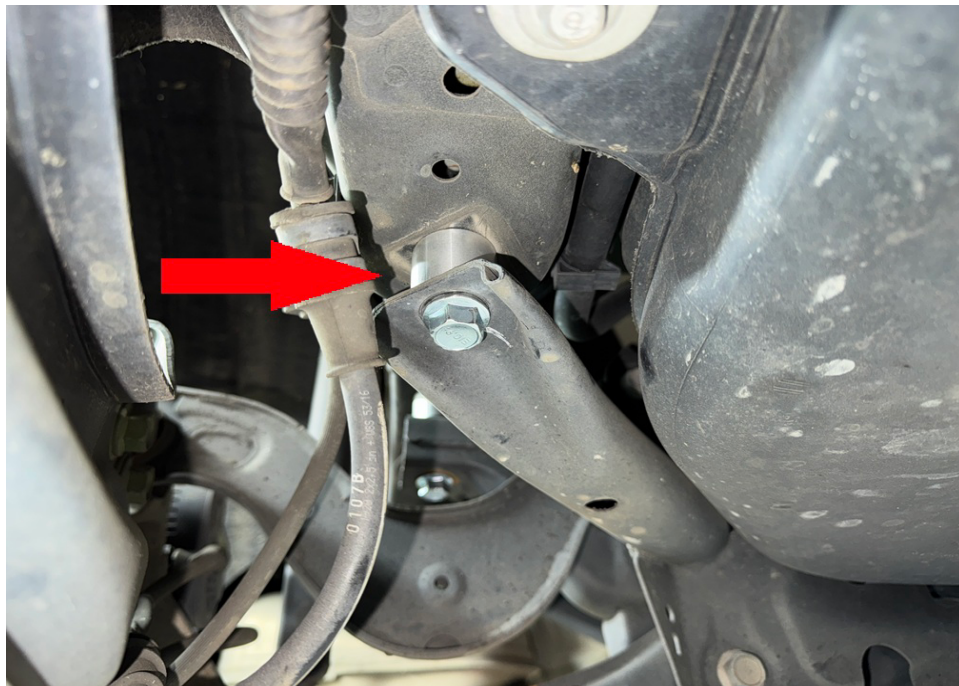

Step 8. Repeat this process with the remaining 4 bolts in the subframe.

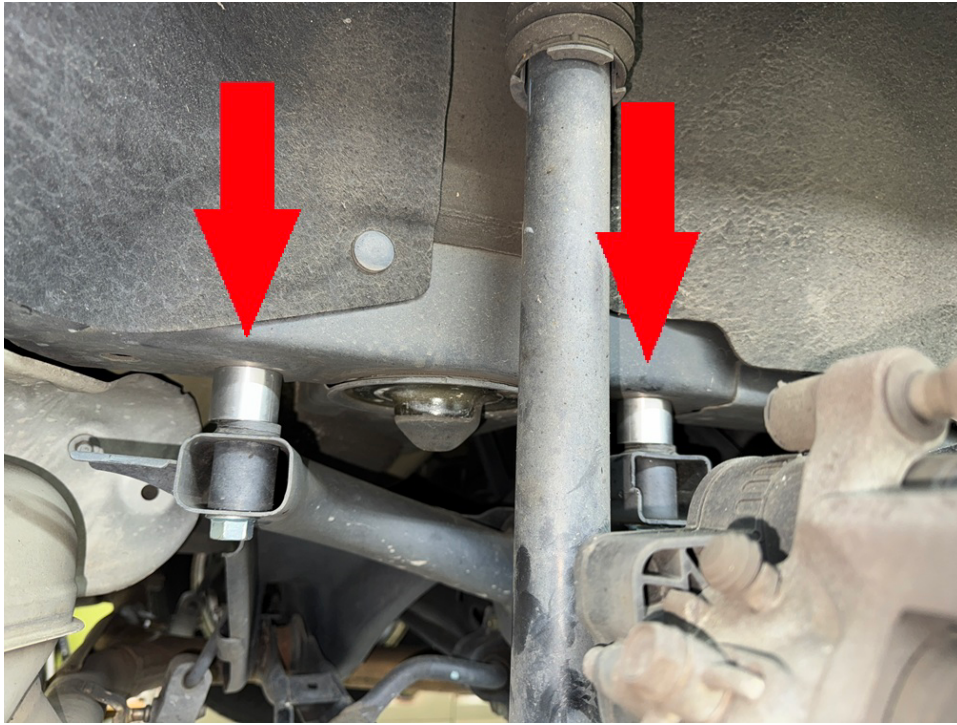

Step 9. Torque all 6 subframe bolts to 85 ft-lb

Step 10. Remove 2 17mm bolts holding driver side trailing arm to body.

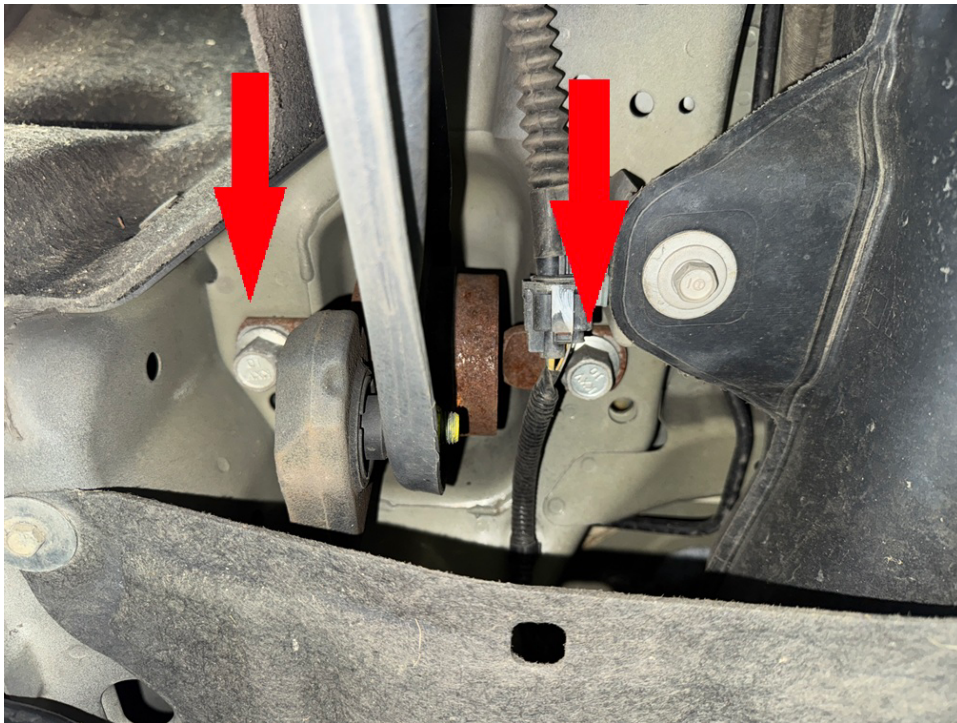

Step 11. Place 1.25x1 M14 spacers between trailing arm and body. Install M14x80 bolts.

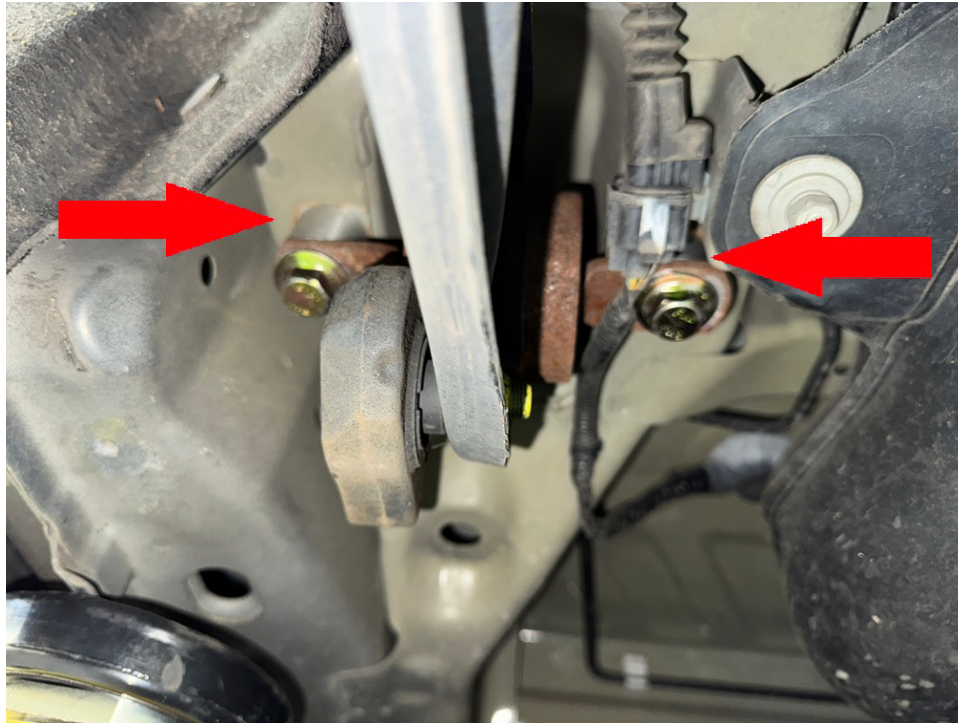
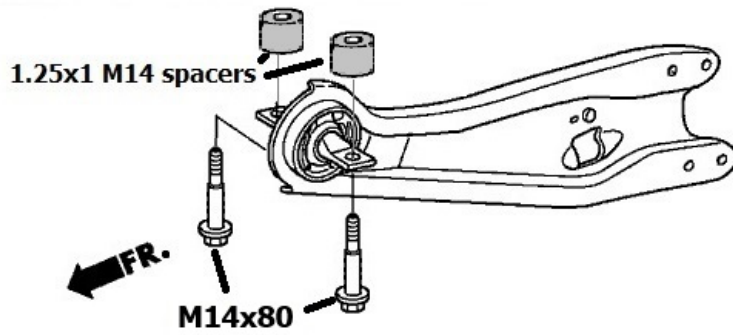

Step 12. Repeat trailing arm spacer installation on passenger side.

Step 13. Support driver side lower control arm with floor jack or screw jack.

Step 14. Remove 2 12mm bolts holding driver side shock absorber into wheel well.

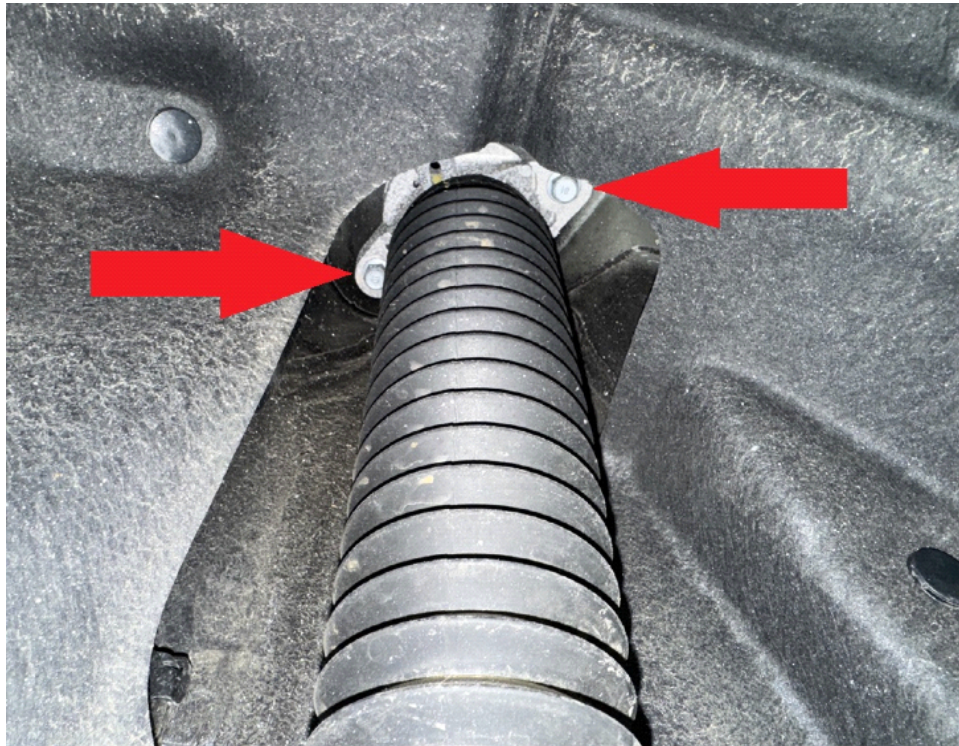

Step 15. Remove bolts holding rear sway bar link and wheel hub to lower control arm on driver side. Loosen, do not remove rear alignment bolt, allowing lower control arm to drop.

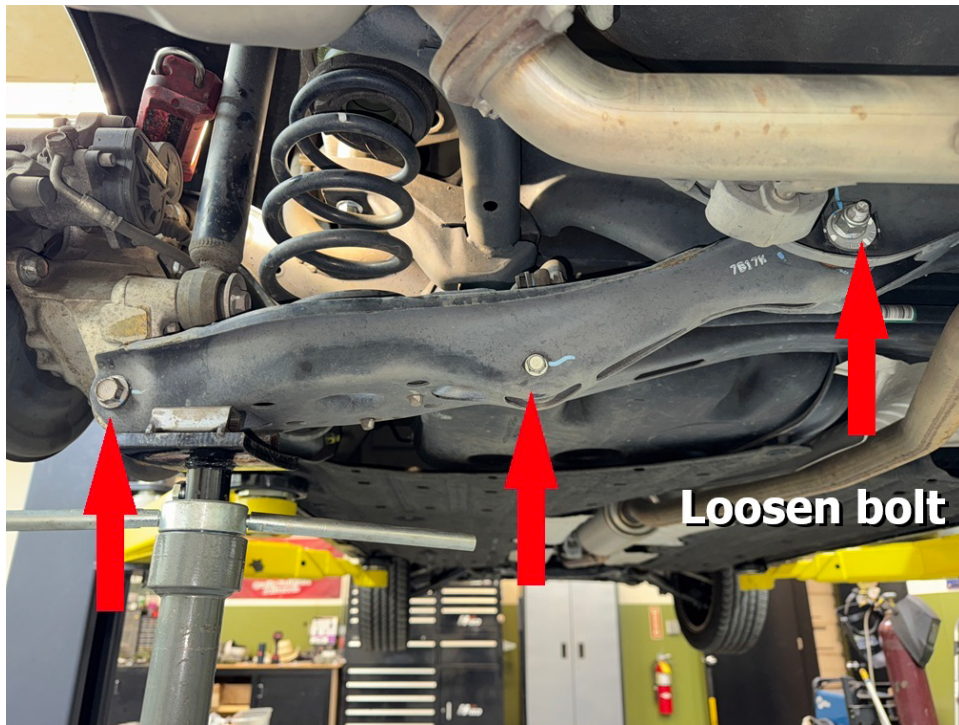

Step 16. Carefully release pressure on spring by lowering jack.

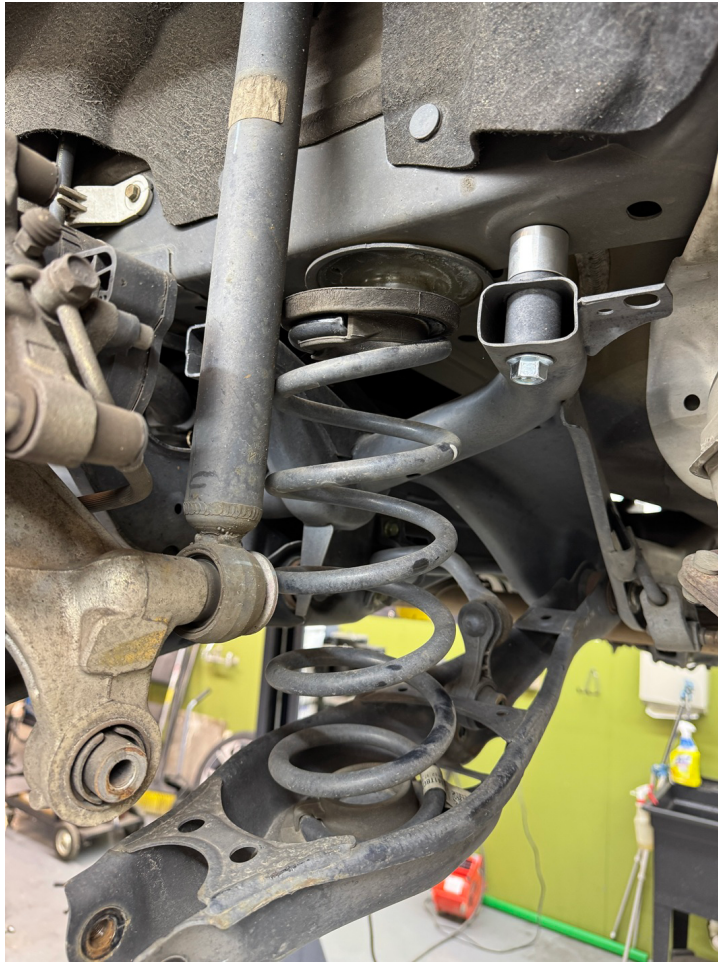

Step 17. Remove spring and place lift spacer on top of rubber isolator as shown.



Step 18. Reinstall spring and spacer. Be sure bottom of spring coil is rotated properly and fully seated in the lower

rubber isolator.



Step 19. Place rear shock spacer between rear shock and body, install M8x70 bolts. torque bolts to 30 ft-lb



Step 20. Use jack to compress the spring and raise the lower control arm back into place.

Step 21. Reinstall bolt holding lower control arm to wheel hub.

Step 22. Reinstall sway bar link bolt and tighten alignment bolt.

Step 23. Repeat installation process for passenger side.

Step 24. Double check all bolts.

Step 25. Reinstall wheels.

Step 26. Get a professional 4-wheel alignment.

Step 27. Find some trails!



Note: Installing a lift kit will change the suspension geometry and will require a 4-wheel alignment.

Warning: Failure to follow the procedures in these installation instructions may result in unsafe handling characteristics, damage to vehicle, or loss of control.

For tech support, please call 1-844- HRG LIFT (474-5438) from 8-4:30 PM EST Mon-Thu 8-3:30 PM Fri or email us 24/7 at support@hrgoffroad.com.

This product is intended for off-road use only!!

Copyright HRG Offroad 2026