



2007-2013 1-inch subframe kit installation guide

Professional installation is recommended

IMPORTANT!

Lifting and modifying the suspension on your vehicle may result in drive line vibrations, damaged bushings, erratic handling characteristics, and shortened suspension component life. HRG Offroad recommends the following:

- Checking and/or replacing worn drive axles with new parts, not remanufactured.
- Checking and/or replacing all worn factory rubber bushings with urethane bushings, such as Prothane.
- Checking and/or replacing worn shock absorbers and bump stops.
- Performing a 4 wheel alignment after working on suspension components.

Lift kits may not be legal for use on public highways in your area. Please check local laws before installing!!

WARNING!

Lifted vehicles are more prone to rolling over.

Some HRG Offroad products are designed to improve off-road capabilities. Modifying the suspension of your vehicle may result in handling characteristics that are different from a factory equipped vehicle. Extreme care must be used to prevent a rollover or loss of control. Always operate your modified vehicle at a reduced speed to ensure your ability to maintain control under all driving conditions. Driving your vehicle in an unsafe manner may result in serious injury or death. HRG Offroad lift kits are designed and tested to work together. HRG Offroad does not recommend combining this lift kit with any other type of suspension or body lift. Always wear your seat belt.

Included in the kit:

- 4 2.75x1" M14 spacers (front subframe)
- 4 3.5x1" M14 spacers (rear subframe)
- 4 1.25x1" M14 spacers (rear trailing arms)
- 6 1.25x1" M12 spacers (front subframe bolt retaining brackets)
- 2 1x1" M10 spacers (passenger side engine mount)
- 2 1x1" M10 spacers (center driveshaft carrier bearing)
- 4 .625x1" M8 spacers (driveshaft safety loops)

4 M8x40mm bolts (driveshaft safety loops)
4 M14x135mm bolts (rear subframe)
4 M14x90mm bolts (rear trailing arms)
2 M10x50mm bolts (center driveshaft carrier bearing)
2 M10x70mm bolts (passenger side engine mount)
6 M12x50mm bolts (front subframe bolt retainer brackets)
1 1" foam seal (steering coupler)

Installation time: Approximately 3-4 hours.

Tools required:

Jack, lug wrench, jack stands, impact wrench, socket extension, 12, 14, 17, 18 and 21mm sockets, 14 and 18mm wrenches, heavy hammer, pry bar, torque wrench, paint pen.

Front installation:

Step 1. Disconnect negative battery terminal.

Step 2. Support engine/transmission with floor jack, taking care not to damage oil pan.

Step 3. Remove 2 M10 bolts holding passenger side engine mount to engine bracket.

Step 4. Remove lower plastic splash guard under front valence to gain access to front main subframe bolts. Take care not to break plastic retainer clips. Save hardware for re-installation.

Note: for steps 6-8 refer to diagram on back page.

Step 5. Remove 4 M12 bolts holding main subframe bolt retainer brackets to body.

Step 6. Loosen but do not remove 4 M14 main subframe bolts allowing subframe to drop approximately one inch.

Step 7. Carefully lower engine/subframe with floor jack, remove main subframe bolts one at a time and slip 2.5x1 M14 spacers between subframe and body, replacing bolts with longer ones provided in the kit as you go. This keeps the subframe secure and aligned during installation.

Step 8. Install 4 1.25x1 M12 spacers between main subframe bolt retainer brackets and body using supplied M12x50 bolts.

Step 9. Install 2 1x1 M10 steel spacers between engine mount and engine bracket, using supplied M10x70mm bolts (see diagram).

**03-15 PILOT/01-13 MDX/06-14
RIDGELINE ENGINE SPACER DIAGRAM
(C) HRG OFF-ROAD 2023**

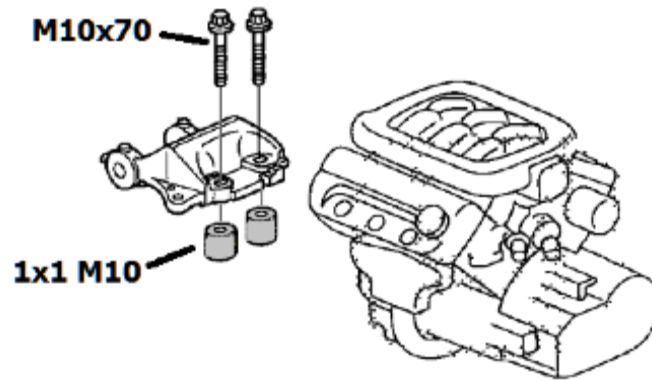

Step 10. Trim plastic splash shield as necessary to fit with lowered subframe, reinstall using original hardware.

Step 11. Under driver dash, remove plastic dust cover on steering column to gain access to steering coupler.

Step 12. If necessary, trim sheet metal for clearance around steering coupler. This can also be done by simply bending the sheet metal back about 1/2 inch around the coupler. Turn steering wheel to verify the coupler has proper clearance.

Step 13. Install foam weather seal between steering rack and body.

Step 14. Re-install dust cover on steering column below interior dashboard.

Step 15. Referring to factory service manual, torque all bolts to spec and mark with paint pen once completed.

Step 16. Reinstall wheels and lower vehicle.

Rear installation:

TIP: Steps 1-6 are performed with the vehicle sitting on the ground.

Step 1. Support rear cross member with floor jack.

Note: for steps 2-6 refer to diagram on back page.

Step 2. Loosen but do not remove 4 main M14 bolts holding subframe to body, lower the subframe enough to install one 2.5x1" M14 spacer between subframe and body.

Step 3. Remove M14 rear subframe bolts one by one, installing remaining 3 spacers and replacing with M14x135 bolts. (refer to diagram)

Step 4. Loosen M10 bolts holding center drive shaft carrier bearing. Remove one bolt, install 1x1" M10 spacer and M10x50 bolt, then repeat process for second bolt.

Step 5. Remove M8 bolts from both front and rear driveshaft safety loops, install (2) 0.625x1" M8 spacer and M8x40 bolts between loops and body.

Step 6. Remove one M14 bolt and loosen second M14 bolt in driver side rear trailing arm. Install 1.25x1" M14 spacers one at a time and replace OEM bolts with supplied M14x90.

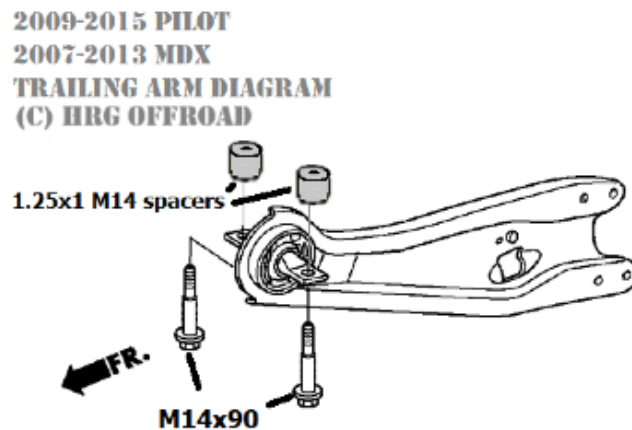

Step 7. Referring to factory service manual, torque all bolts to spec and mark with paint pen once completed.

Step 8. Get a professional alignment.

Note: Installing a subframe kit will change the suspension geometry and will require a 4 wheel alignment, and possibly front/rear camber correction kits.

Warning: Failure to follow the procedures in these installation instructions may result in unsafe handling characteristics, damage to

vehicle, or loss of control.

For tech support, please call 1-844- HRG LIFT (474-5438) from 8-4:30 PM EST Mon-Thu 8-3:30 PM Fri or email us 24/7 at support@hrgoffroad.com.

This product is intended for off-road use only!!

Copyright HRG Offroad. 2023

